



**Gianni
Ferrari**

TURBO



**CATALOGO PARTI DI RICAMBIO
CATALOGUE PIECES DETACHEES
ERSATZTEILKATALOG
PARTS MANUAL**

10.01.2008



**Gianni
Ferrari**



**INDICE****PART LIST**

WIELEN	T6-01	WHEELS
FRAME	T6-02	FRAME
KABINE STEUN	T6-03	WINGS BRACKET
HEF MAAIERS ZIJKANT	T6-04	WINGS LIFT
ARM ZIJ MAAIERS	T6-05	WINGS TRANSLATION
HYDRAULIEK ZIJ MAAIER	T6-06	WINGS HYDRAULIC SYSTEM
ROLBEUGEL STEUNEN	T6-07	BUMPERS & VERTICAL RODS
FRAME PLAAT & CILINDER	T6-08	CROSSBAR ROCKER PDP CYLINDER
P.T.O. AS	T6-09	PTO SHAFT
P.T.O. REM	T6-10	PTO BRAKE
OLIETANK HYDR. SYSTEEM	T6-11	HYDRAULIC OIL RESERVOIR
HYDR. SNAAR SPANNER	T6-12	PDP TIGHTENER
MOTOR	T6-13	ENGINE
V-SNAAR SPANNER MOTOR	T6-14	ENGINE BELT STRETCHER
UITLAAT	T6-15	EXHAUST
LUCHTFILTER	T6-16	AIR FILTRE
RADIATEUR	T6-17	RADIATOR
FRAME MOTORKAP	T6-18	BODY FRAME
MOTORKAP	T6-19	HOOD
BRANDSTOF LEIDINGEN ENC.	T6-20	FUEL PIPING
BRANDSTOF TANK	T6-21	FUEL TANK
ACHTERLICHTEN & SPIEGEL	T6-22	ROPS FRAME
ZWAAILAMP	T6-23	ROPS VERTICAL RODS
HEF KABINE	T6-24	ROPS LIFT
STUUR KOLOM	T6-25	STEERING COLUMN
ZITTING	T6-26	SEAT & CONSOLE
FRAME ONDER DE ZITTING	T6-27	OPERATOR PLATFORM
VOETEN STEUN	T6-28	FOOT REST
VOET PEDALEN	T6-29	FOOT DRIVE
HYDR. STUUR VENTIEL	T6-30	HYDRO-STEERING UNIT
STUUR CILINDER	T6-31	HYDRO-STEERING CYLINDER
SPOORSTANG HYDR. DELEN	T6-32	HYDRO-STEERING ROD & SLIDING
DIFFERENCIEEL VOORAS	T6-33	FRONT AXLE CENTER GEAR
EINDAANDRIJVING VOORAS	T6-34	FRONT AXLE REDUCTION GEAR
DIFFERENCIEEL SLOT	T6-35	DIFFERENTIAL LOCK CONTROL
FUSEE WD ACHTERAS	T6-36	REAR AXLE STEERING JOINT
DIFFERENCIEEL ACHTERAS	T6-37	REAR AXLE CENTER GEAR
HYDRAULISCHE AANDRIJF POMP	T6-38	PUMP DRIVE
BEDIENING VAN DE HYDROSTAAT	T6-39	PUMP CONTROL
VOORUIT RIJ HANDEL	T6-40	FORWARD MOTION LEVER
HYDRAULIEK LEIDINGEN	T6-41	HYDRAULIC PIPING
HYDRAULISCHE AANSLUITINGEN	T6-42	HYDRAULIC FITTINGS
HYDRAULISCHE AANSTURINGEN	T6-43	HYDRAULIC MOTORS
FRONT HEF	T6-44	FRONT HYDRAULIC POWER LIFT

**TABLES DES MATRIERES****STÜCK LISTE**

ROUES	T6-01	RÄDER
CHASSIS	T6-02	RAHMEN
ETRIERS AILES	T6-03	BÜGEL ZU SEITENFLÜGEL
RELEVAGE AILES	T6-04	SEITENFLÜGEL- AUSHEBUNG
TRANSLATION AILES	T6-05	SEITENFLÜGEL- BEWEGUNG
INSTALLATION HYDRAULIQUE AILES	T6-06	HYDR.ANLAGE DER SEITENFLÜGELN
PARE-CHOCS & MONTANTS	T6-07	STOSSFÄNGER UND STÄNDER
TRAVERSE CULBUTEUR VERIN PDP.	T6-08	ZYLINDERSTANGE ZU ABTRIEB (PDP)
ARBRE PDP	T6-09	ABTRIEBSZELLE (PDP)
FREIN PDP	T6-10	ABTRIEBSBREMSE (PDP)
RESERVOIR HUILE HYDRAULIQUE	T6-11	ÖLTANK
PDP TENDEUR	T6-12	ABTRIEBS-SPANNROLLE (PDP)
MOTEUR	T6-13	MOTOR
TENDEUR MOTEUR	T6-14	MOTORSPANNROLLE
ECHAPPEMENT	T6-15	AUSPUFF
FILTRE AIR	T6-16	LUFTFILTER
RADIATEUR	T6-17	KÜHLER
CADRE DU CAPOT	T6-18	HAUBERAHMEN
CAPOT	T6-19	HAUBE
TUYAUTERIE DIESEL	T6-20	KRAFTSTOFFSCHLÄUCHE
RESERVOIR DU CARBURANT	T6-21	KRAFTSTOFFTANK
ROPS CADRE	T6-22	ROPSRAHMEN
ROPS CADRE	T6-23	ROPSSTÄNDER
RELEVAGE ROPS	T6-24	ROPSKIPPUNG
COLONNE DIRECTION	T6-25	LENKSÄULE
SIEGE ET CONSOLE	T6-26	SITZ MIT STEUERPULT
PLATE-FORME OPERATEUR	T6-27	BEDIENER-ARBEITSPLATZ
MARCHEPIED	T6-28	FUSSBRETT
PEDALIER DE CONDUITE	T6-29	PEDAL STEUERUNG
UNITE HYDRO-DIRECTION	T6-30	STEUER- HYDROLENKUNG
VERIN HYDRO-DIRECTION	T6-31	ZYLINDER ZU HYDROLENKUNG
ENTRETOISE & COULISSE HYDRO-DIRECTION	T6-32	HYDROLENKUNG-VERSCHIEBBARE ZUGSTANGE
ESSIEU AVANT- BOITIER CENTRAL	T6-33	MITTELACHSE VORNE
ESSIEU AVANT- BOITIER REDUCTEUR	T6-34	REDUZIERER VORDERACHSE
COMMANDE BLOCAGE DIFFERENTIEL	T6-35	STEUER- DIFFERENTIALSPERRE
ESSIEU ARRIERE - JOINT DIRECTION	T6-36	GELENK- HINTERACHSE
ESSIEU ARRIERE - BOITIER CENTRAL	T6-37	MITTELACHSE HINTEN
ENTRAINEMENT POMPE	T6-38	PUMPENHALTER
COMMANDE POMPE	T6-39	PUMPENSTEUERUNG
LEVIER AVANCEMENT	T6-40	FAHRSCHWINGE
TUYAUTERIE HYDRAULIQUE	T6-41	LEITUNGEN -HYDR. GETRIEBE
RACCORDS HYDRAULIQUES	T6-42	SCHLÄUCHE- HYDR. GETRIEBE
MOTEURS HYDRAULIQUES	T6-43	HYDR. MOTORE
RELEVAGE HYDRAULIQUE AVANT	T6-44	HYDR. FRONTAUSHEBUNG



**Gianni
Ferrari**

T6 - 01

20/12/2005

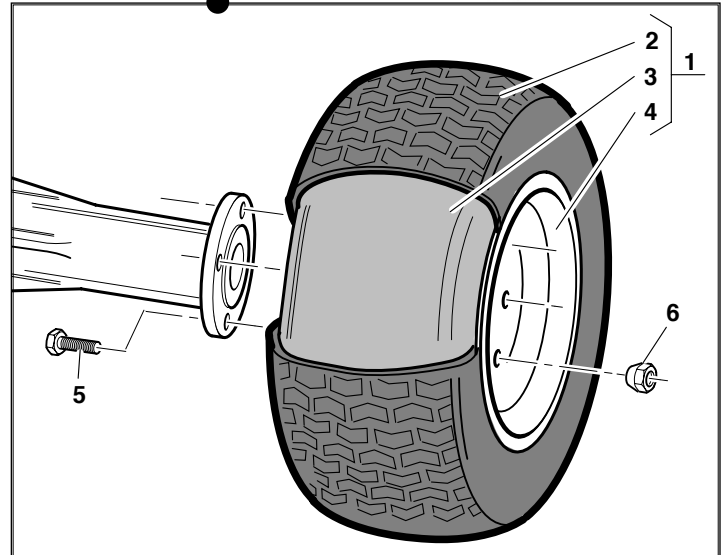
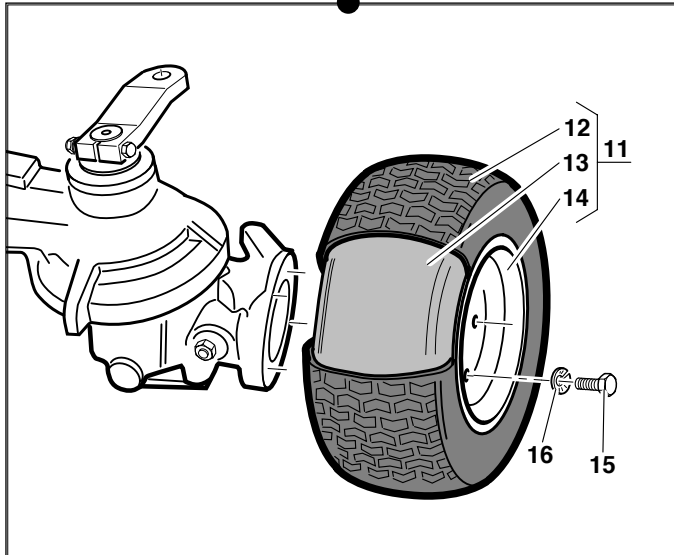
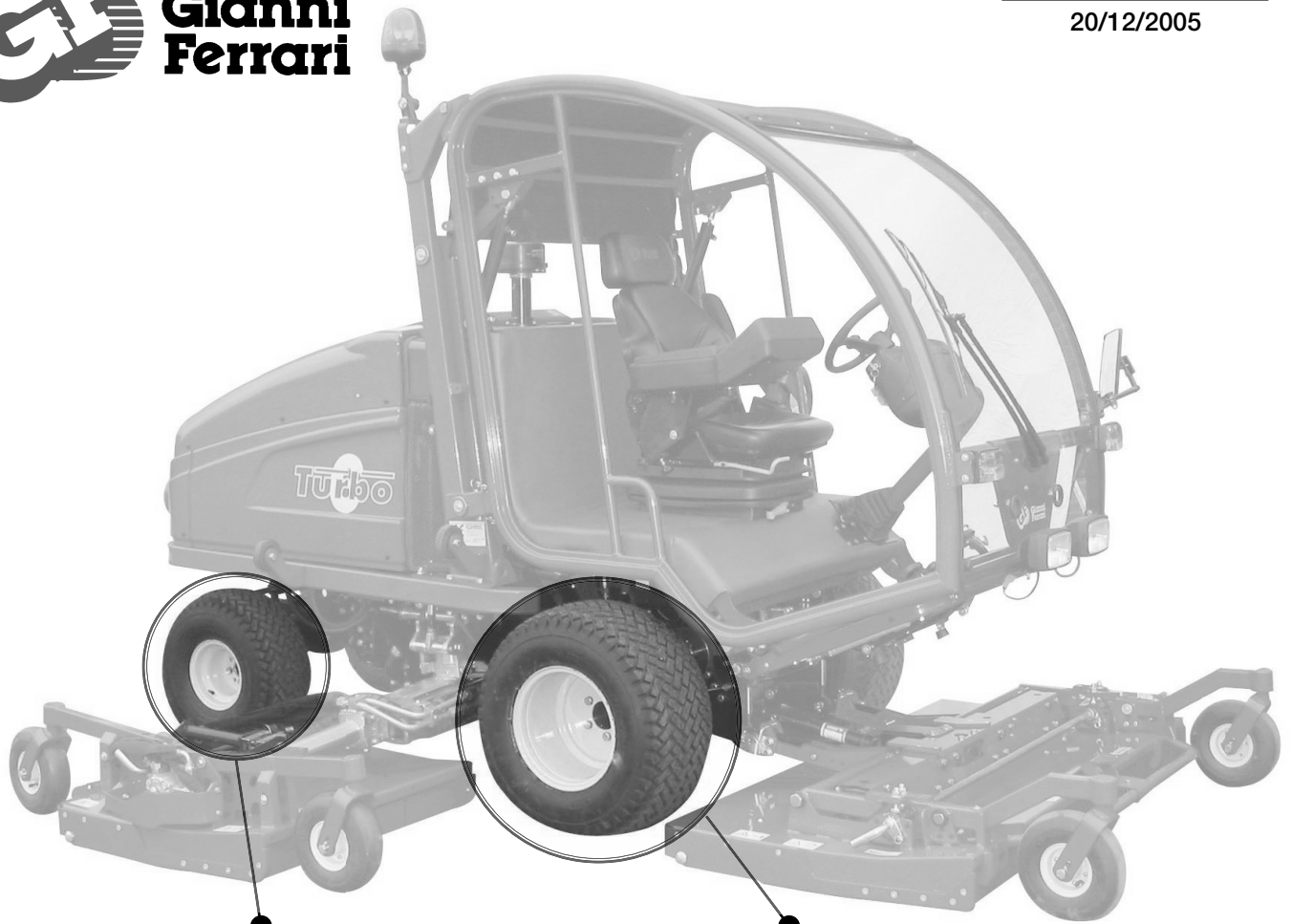

Ref.	Code	Q.ty	Leg.	PR	Tread
1	00.72.00.0070	2	26 x 1200 - 12	8	SOFT GRIP
2	00.59.00.1070	2	26 x 1200 - 12	=	SOFT GRIP
3	00.59.01.1070	2			
4	00.16.00.0070	2			
5	00.92.08.3081	10			
6	00.26.08.0020	10			
11	00.72.00.0150	2	20 x 1000 - 8	4	GARDEN
12	00.59.00.0070	2	20 x 1000 - 8	=	GARDEN
13	00.59.01.0070	2			
14	00.16.00.0080	2			
15	00.92.07.3051	8			
16	00.68.05.0010	8			



**Gianni
Ferrari**

T6 - 02

30/06/2006

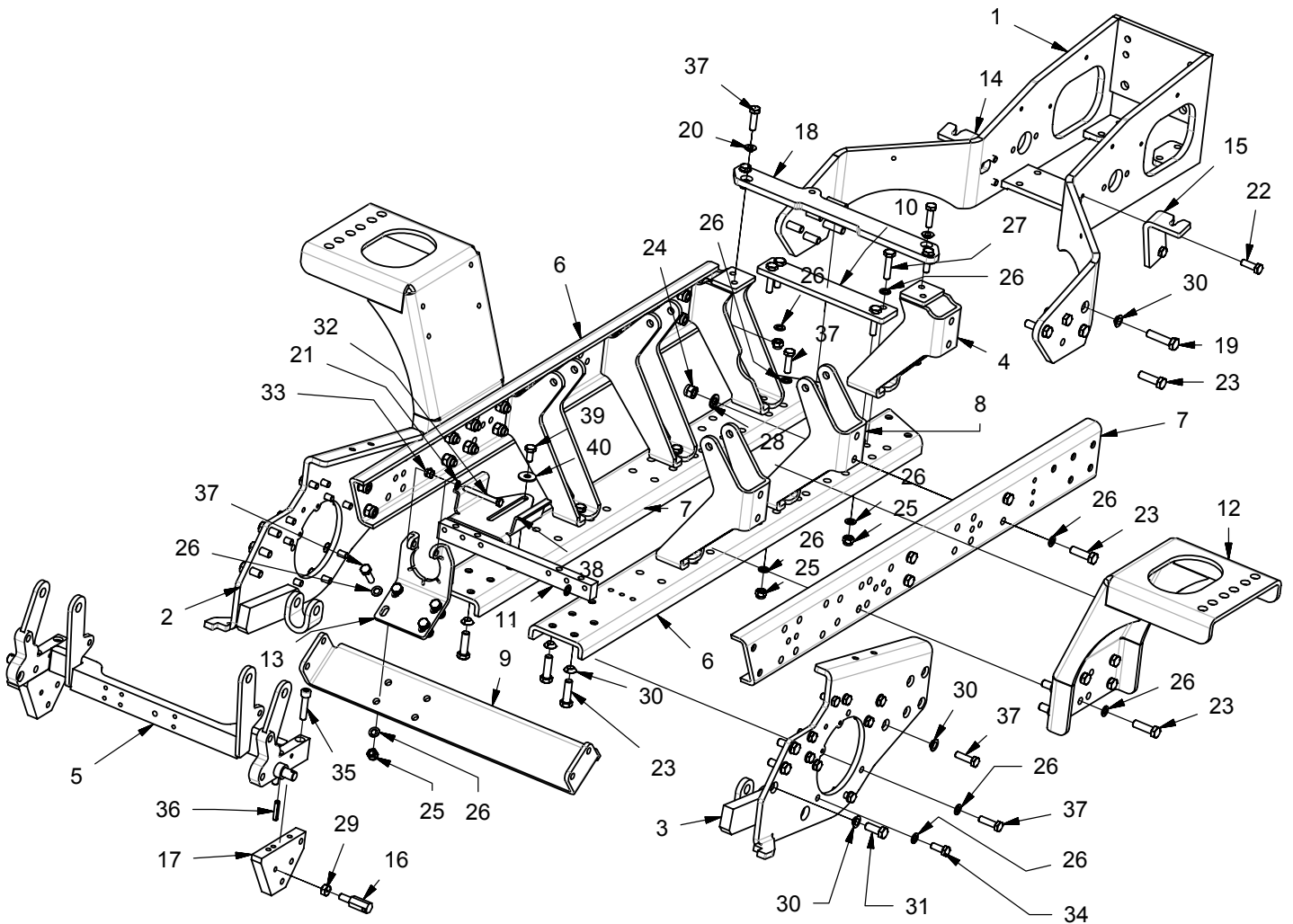

01.90.00.2231

Ref.	Leg.	Code	Q.ty	Ref.	Leg.	Code	Q.ty	Ref.	Leg.	Code	Q.ty
13		01.50.01.0500	1	26		00.68.01.0040	86	40		00.68.02.0070	1
12		01.50.01.0790	2	25		00.26.04.0070	20	39		00.92.06.1040	1
11		01.50.01.0340	1	24		00.26.04.0080	34	38		01.50.01.0570	1
10		01.50.01.0350	1	23		00.92.07.0090	30	37		00.92.06.1090	24
9		01.50.01.0380	1	22		00.92.06.1080	4	36		00.83.14.0036	2
8		01.50.00.8820	4	21		00.68.01.0030	2	35		00.90.07.0140	4
7		01.50.01.0230	2	20		00.68.05.0008	10	34		00.92.06.1060	14
6		01.50.01.0220	2	19		00.92.07.0110	4	33		00.26.04.0060	1
5		01.50.01.1760	1	18		01.50.01.1110	1	32		00.92.05.0180	1
4		01.50.01.1100	2	17		01.50.01.0620	2	31		00.92.07.1070	6
3		01.50.01.0330	1	16		01.40.00.3760	2	30		00.68.05.0010	24
2		01.50.01.0320	1	15		01.50.01.0520	1	29		00.26.02.0080	2
1		01.50.01.0290	1	14		01.50.01.0510	1	28		00.68.01.0050	8
								27		00.92.06.0110	4



**Gianni
Ferrari**

T6 - 03

30/06/2006

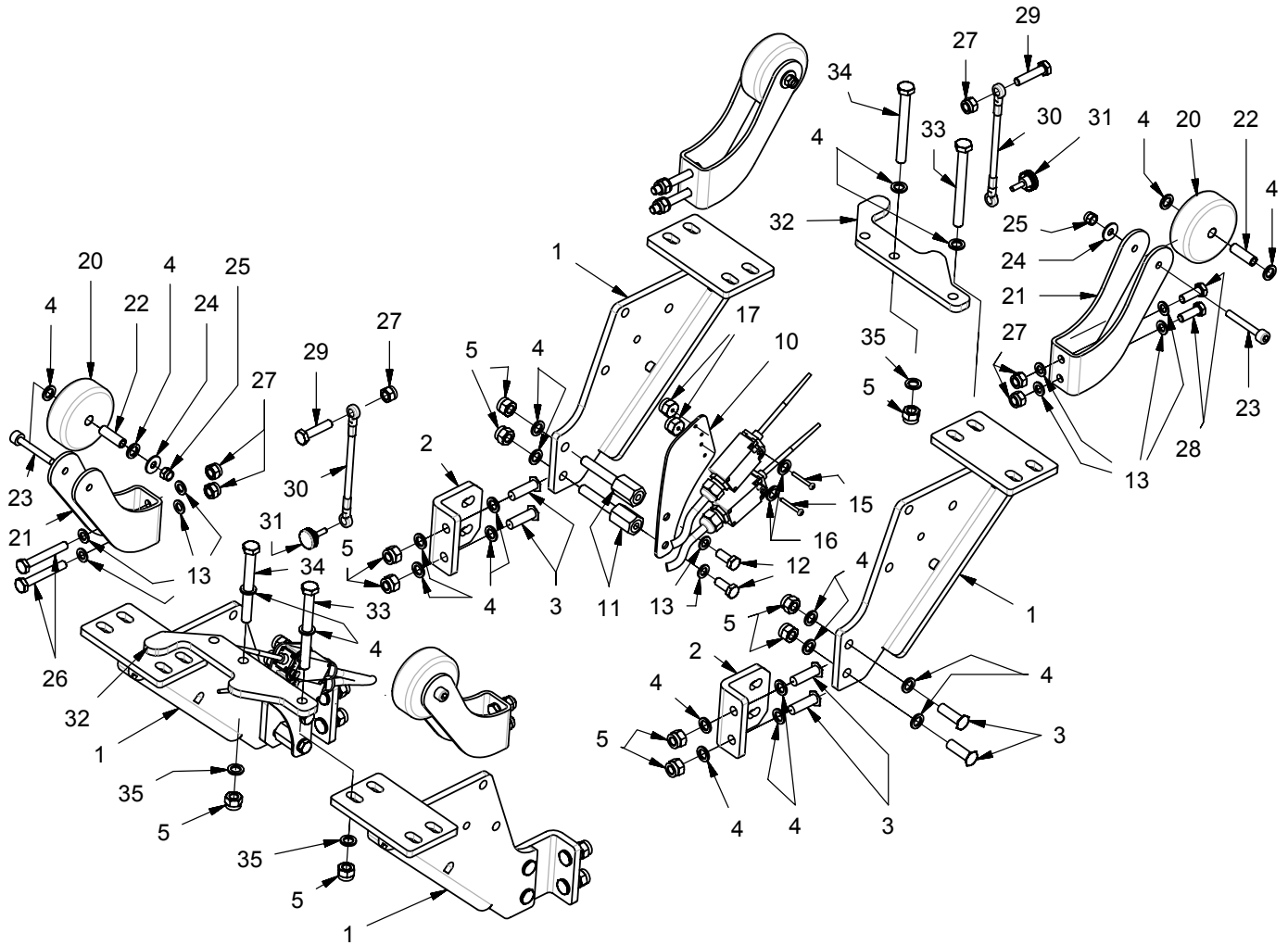

00.90.00.2271

Ref.	Leg.	Code	Q.ty	Ref.	Leg.	Code	Q.ty	Ref.	Leg.	Code	Q.ty
13		00.68.01.0040	20	25		00.26.04.0060	3	35		00.68.08.0346	4
12		00.92.06.1060	4	24		00.68.02.0050	4	34		00.92.07.0220	2
11		01.40.00.0730	4	23		00.90.06.3170	4	33		00.92.07.0230	2
10		01.50.01.1470	2	22		00.72.00.0221	4	32		01.50.01.1950	2
5		00.26.04.0080	20	21		01.50.01.0480	4	31		00.45.01.0127	2
4		00.68.01.0050	40	20		00.72.00.0250	4	30		01.50.01.1880	2
3		00.92.07.0090	12	17		00.26.04.0020	8	29		00.92.06.0110	2
2		01.50.01.0450	4	16		00.68.01.0009	8	28		00.92.06.1080	4
1		01.50.01.0440	4	15		00.91.04.0110	8	27		00.26.04.0070	11
								26		00.92.06.0160	4

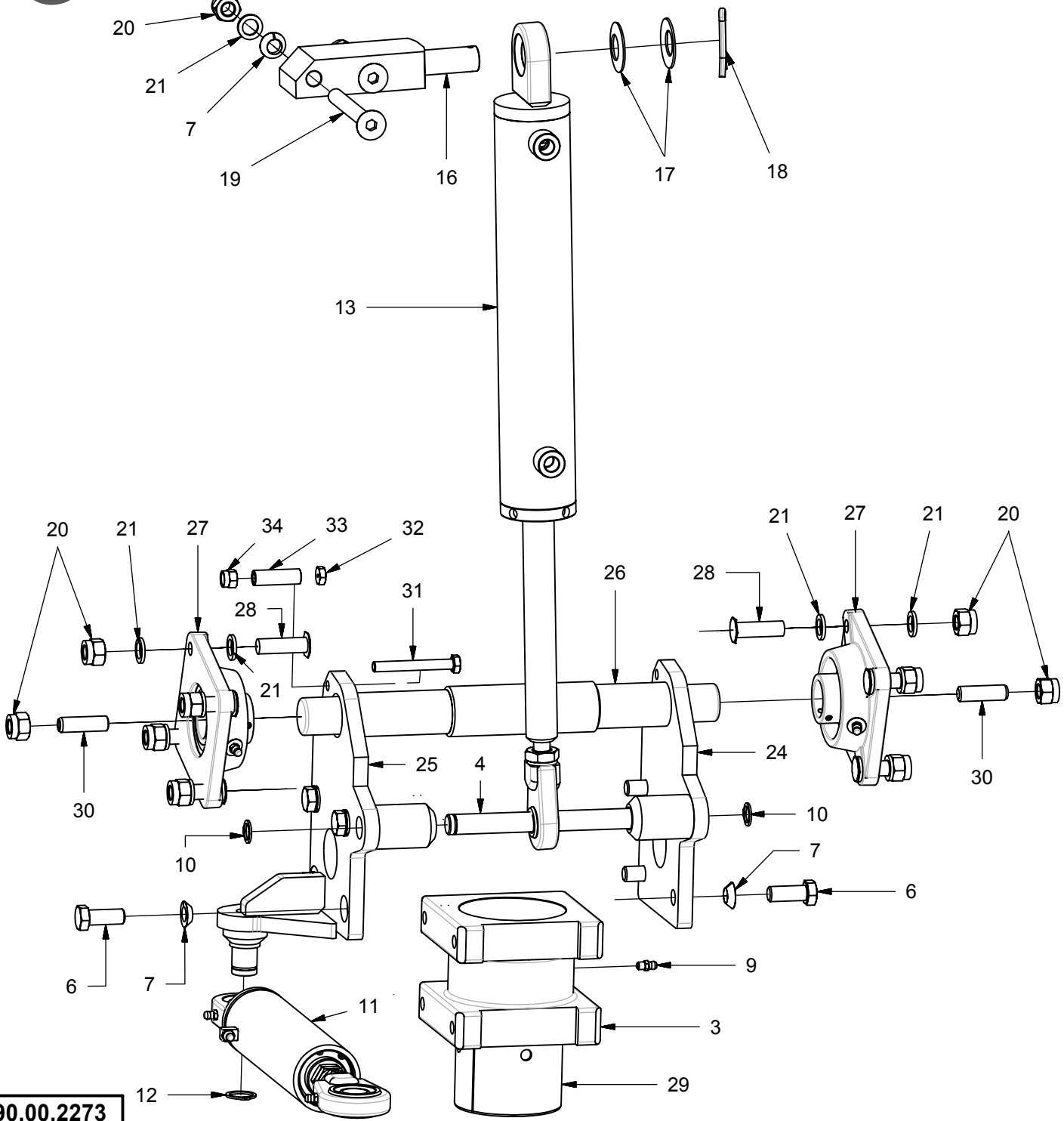
00.90.00.2273

Ref.	Leg.	Code	Q.ty	Ref.	Leg.	Code	Q.ty	Ref.	Leg.	Code	Q.ty
13		00.58.00.0120	1	25	RH	01.50.01.1170	1	34		00.26.04.0060	1
12		00.03.10.0020	1	24	LH	01.50.01.1200	1	33		00.72.00.0221	1
11		01.90.00.2090	1	24	RH	01.50.01.1190	1	32		00.26.03.0060	1
10		00.03.10.0016	2	21		00.68.01.0050	18	31		00.92.05.1170	1
9		00.42.00.0010	1	20		00.26.04.0080	12	30		00.96.07.0110	2
7		00.68.05.0010	10	19		00.95.07.0140	2	29		00.10.80.0101	1
6		00.92.07.1070	8	18		00.18.04.0075	1	28		00.92.07.0090	8
4		01.40.00.3460	1	17		01.48.00.0186	2	27		00.24.01.0302	2
3		01.40.00.3620	1	16		01.50.01.0150	1	26		01.40.00.4000	1
								25	LH	01.50.01.1180	1

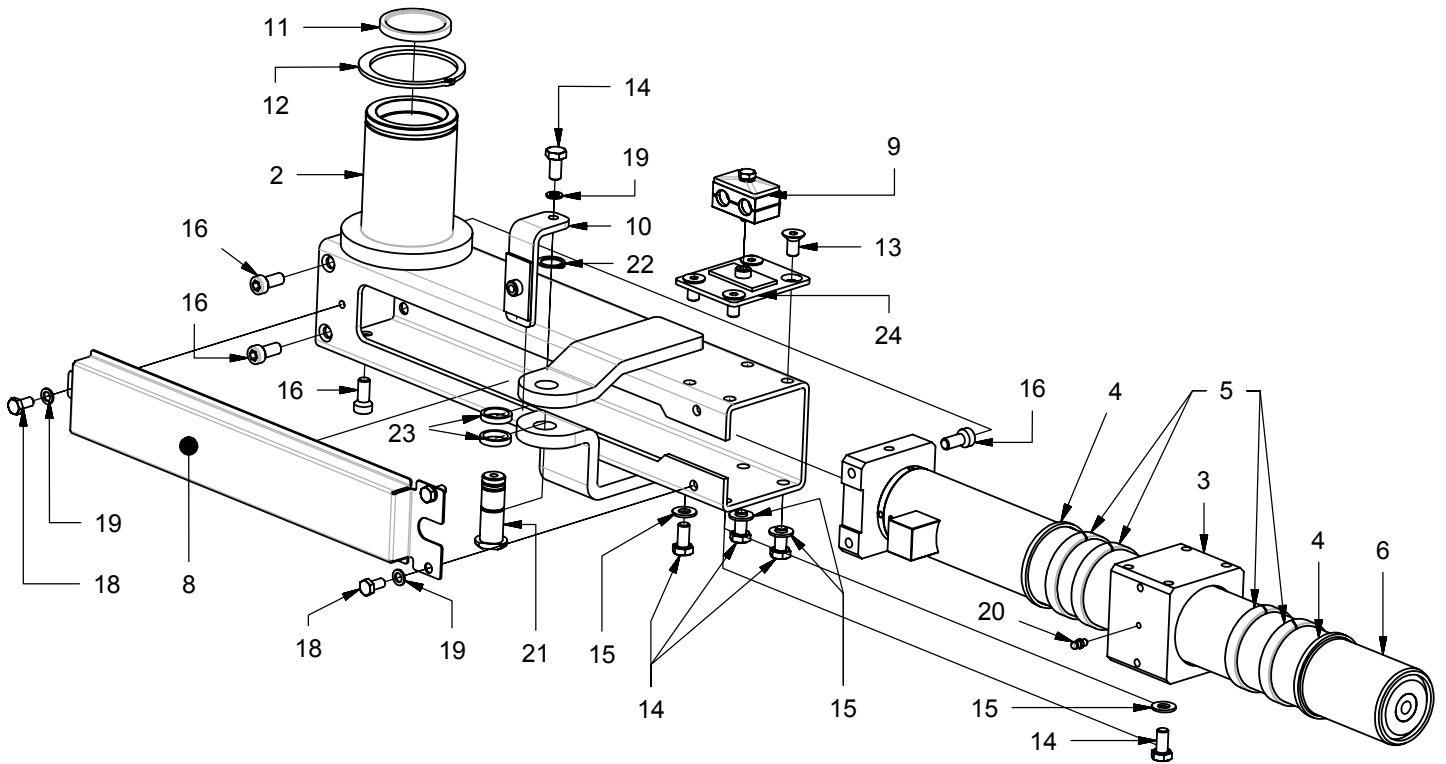
01.90.00.2275

Ref.	Leg.	Code	Q.ty	Ref.	Leg.	Code	Q.ty	Ref.	Leg.	Code	Q.ty
9		00.41.00.0441	1	16		00.90.07.0081	5	24		01.50.01.1580	1
8		01.50.01.0160	1	15		00.68.01.0040	4	23		01.40.00.3970	2
6		00.58.00.0130	1	14		00.92.06.1040	5	22		00.03.10.0020	1
5		00.06.26.0070	4	13		00.95.06.0040	4	21		01.50.00.2310	1
4		00.06.25.0070	2	12		00.03.10.0080	1	20		00.42.00.0010	1
3		01.40.00.3560	1	11		00.07.06.0062	1	19		00.68.01.0030	4
2	LH	01.50.00.9040	1	10		01.50.01.0860	1	18		00.92.05.1040	3
2	RH	01.50.00.9030	1								

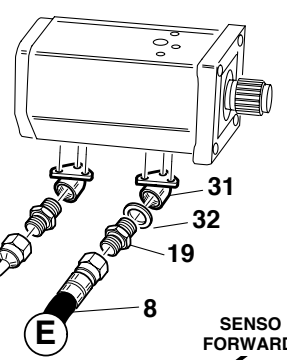
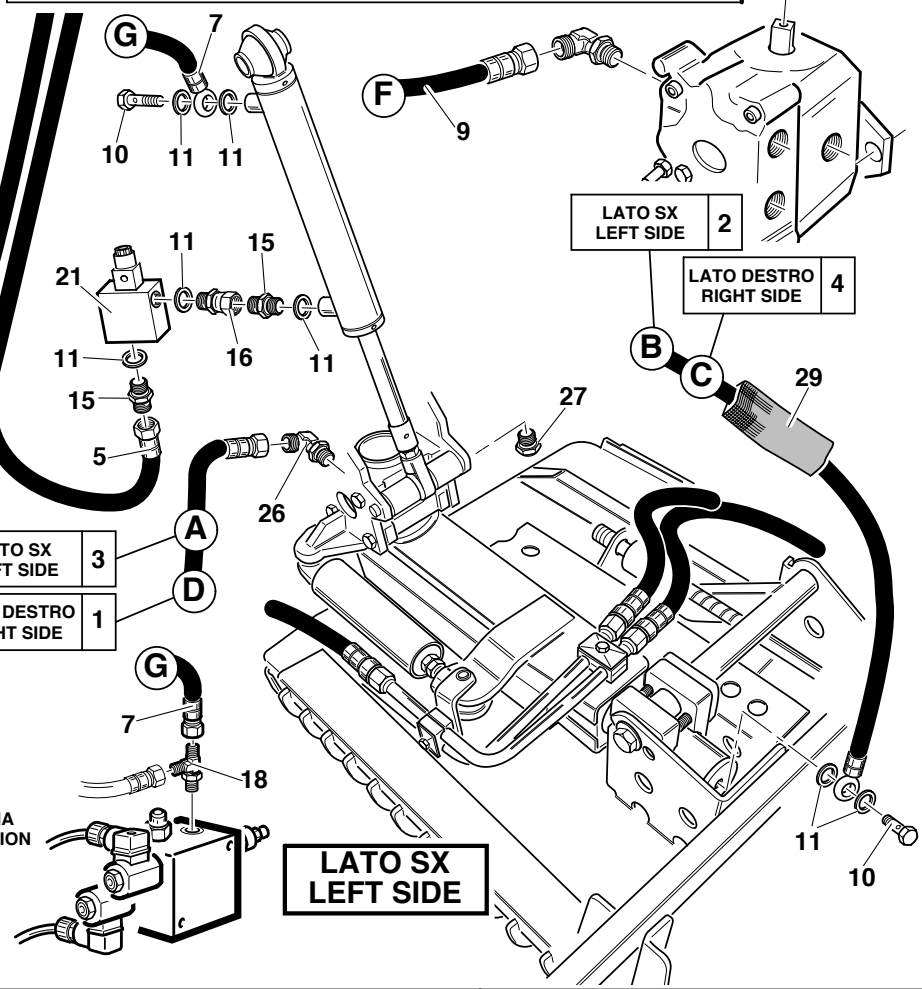
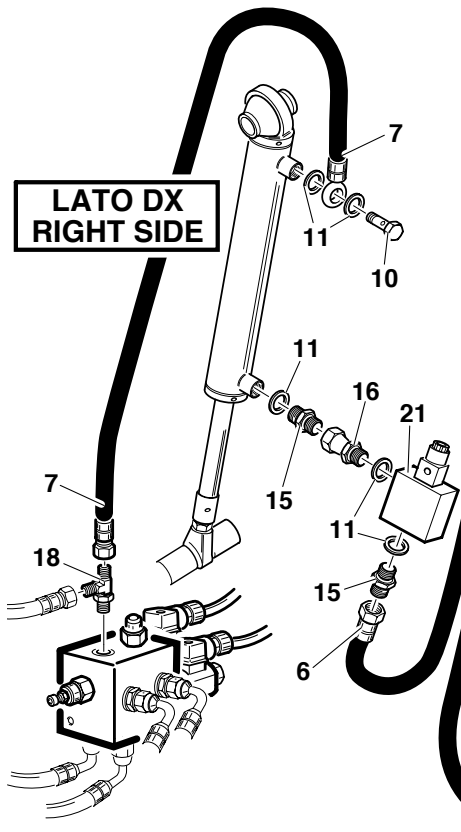
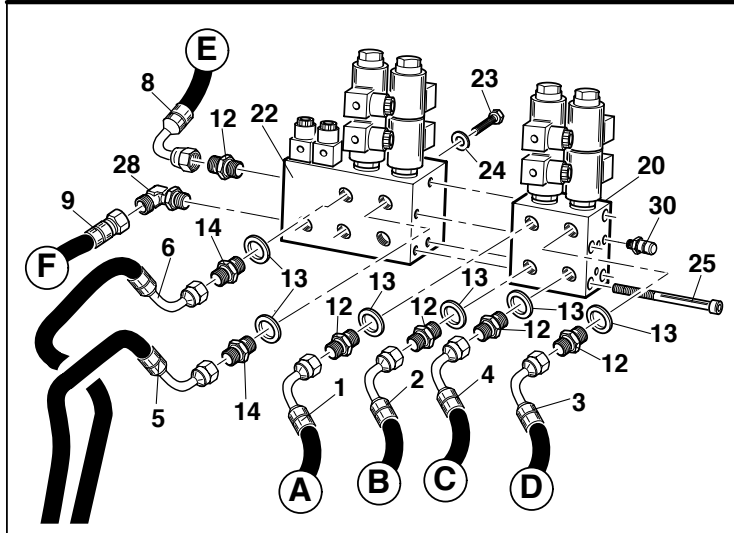
01.90.00.2276

Ref.	Leg.	Code	Q.ty	Ref.	Leg.	Code	Q.ty	Ref.	Leg.	Code	Q.ty
1		00.41.00.2270	1	12		00.41.00.0110	5	24		00.68.01.0030	4
2		00.41.00.2280	1	13		00.41.00.0070	6	25		00.90.06.0230	4
3		00.41.00.2290	1	14		00.41.00.0452	2	26		00.41.00.0874	2
4		00.41.00.2300	1	15		00.41.00.0450	4	27		00.85.02.0071	2
5		00.41.00.2310	1	16		00.41.00.2821	2	28		00.41.00.0875	1
6		00.41.00.2320	1	18		00.41.00.2101	2	29		00.07.01.0186	m 3,8
7		00.41.00.2330	2	19		00.41.00.0784	1	30		00.41.00.3084	1
8		00.41.00.2490	1	20		00.41.00.2230	1	31		00.41.00.0181	1
9		00.41.00.2500	1	21		00.41.00.2260	2	32		00.41.00.0071	1
10		00.41.00.0120	4	22		00.41.00.2220	1				
11		00.41.00.0060	14	23		00.92.05.1070	4				

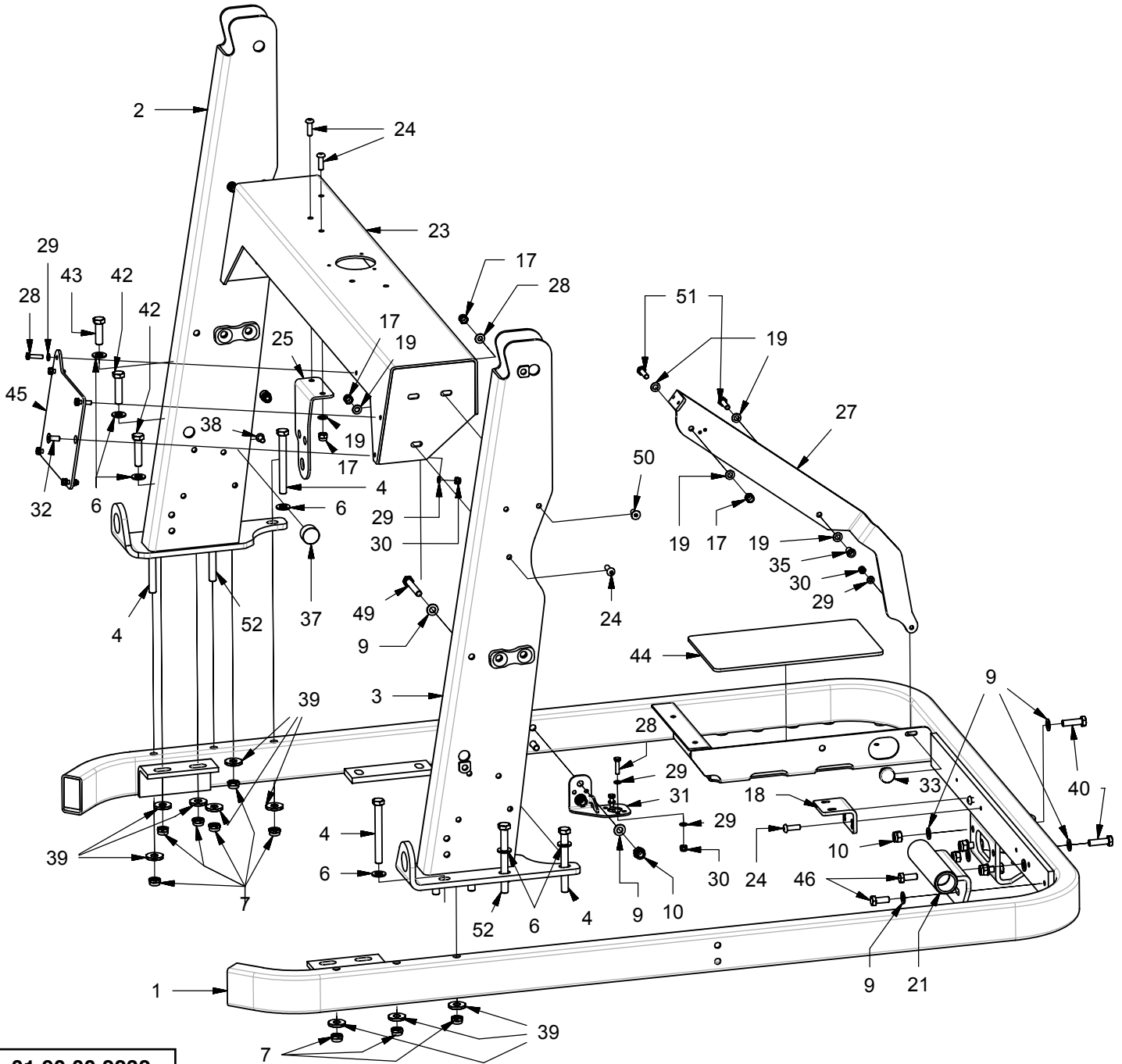

01.90.00.2232

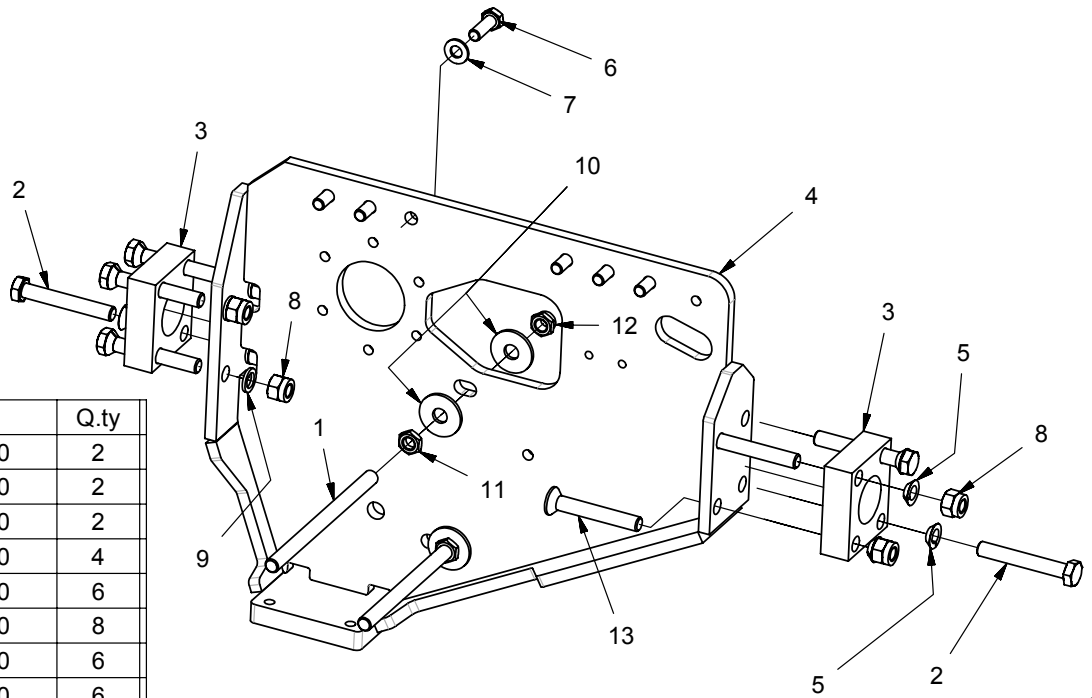
Ref.	Leg.	Code	Q.ty	Ref.	Leg.	Code	Q.ty	Ref.	Leg.	Code	Q.ty
21		01.50.01.0910	1	37		00.74.00.4031	1	52		00.92.07.0230	2
19		00.68.01.0030	11	35		00.66.01.0080	1	51		00.92.05.1100	2
18		01.50.01.1160	1	33		00.45.01.0035	1	50		00.95.05.0040	3
17		00.26.04.0060	8	32		00.95.04.0080	3	49		00.92.06.1150	2
10		00.26.04.0070	6	31		01.50.01.1480	1	46		00.92.06.1060	2
9		00.68.01.0040	14	30		00.26.04.0040	9	45		01.50.01.1830	1
7		00.26.04.0080	12	29		00.68.01.0020	16	44		01.29.00.0100	1
6		00.68.01.0050	12	28		00.92.03.1090	7	43		00.92.07.0090	2
4		00.92.07.0220	4	27		01.50.01.1220	1	42		00.92.07.0110	4
3		01.50.01.1570	1	25		01.50.01.0880	1	40		00.92.06.1090	4
2		01.50.01.1560	1	24		00.90.06.3100	7	39		00.68.08.0346	12
1		01.50.01.0370	1	23		01.50.01.0360	1	38		00.90.06.3060	1

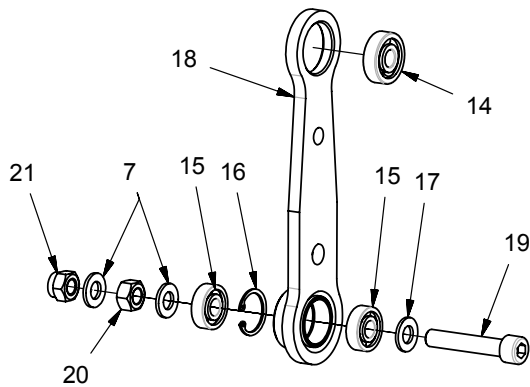

01.90.00.2251

Ref.	Leg.	Code	Q.ty
13		00.95.07.0110	2
12		00.26.05.0080	2
11		00.26.03.0090	2
10		00.68.02.0080	4
9		00.68.01.0050	6
8		00.26.04.0080	8
7		00.68.01.0040	6
6		00.92.06.1080	6
5		00.68.05.0010	8
4		01.50.01.0400	1
3		01.50.01.0490	2
2		00.92.07.0170	6
1		01.40.00.4040	2



01.90.00.2252

Ref.	Leg.	Code	Q.ty
21		00.26.04.0070	1
20		00.26.01.0080	1
19		00.90.07.0160	1
18		01.50.01.0240	1
17		00.68.08.0233	1
16		00.03.09.0026	1
15		00.22.00.0111	2
14		00.22.10.3001	1
7		00.68.01.0040	2

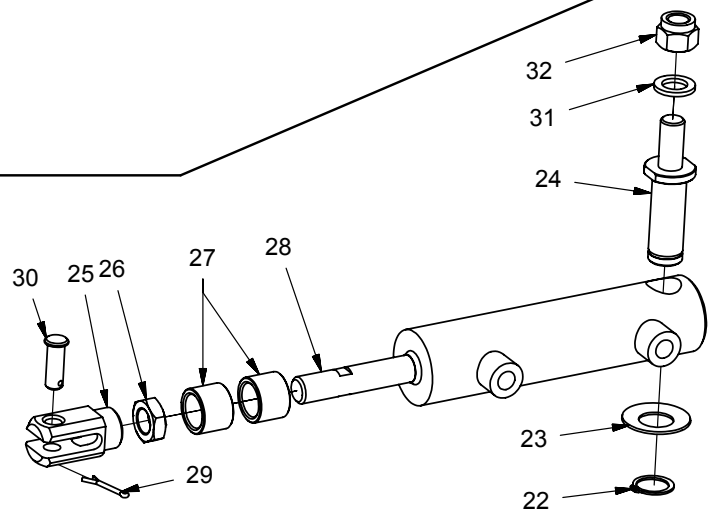

01.90.00.2253

Ref.	Leg.	Code	Q.ty
32		00.26.04.0090	1
31		00.68.01.0060	1
30		01.33.03.0022	1
29		00.18.04.0043	1
28		00.58.00.0040	1
27		01.40.00.2180	2
26		00.26.03.1110	1
25		01.40.00.3950	1
24		01.40.00.3930	1
23		00.48.00.0186	1
22		00.03.10.0020	1

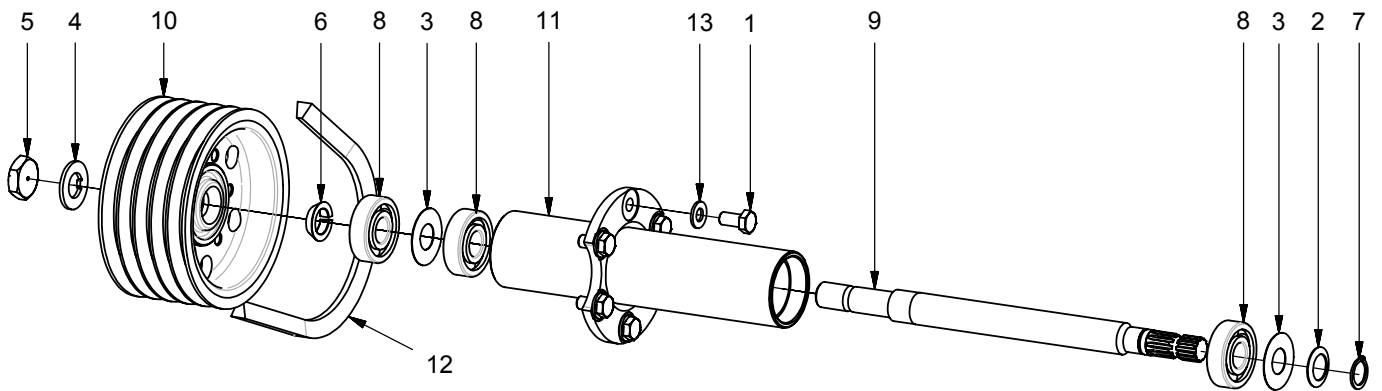

01.90.00.2254

Ref.	Leg.	Code	Q.ty	Ref.	Leg.	Code	Q.ty
6		01.40.00.0710	1	13		00.68.01.0040	6
5		00.26.03.1130	1	12		00.17.01.1450	5
4		01.40.00.1050	1	11		01.50.01.0630	1
3		01.40.00.2030	2	10		00.61.00.0640	1
2		00.48.01.0021	1	9		01.40.00.3920	1
1		00.92.06.1040	6	8		00.22.20.5202	3
				7		00.03.10.0020	1



Gianni Ferrari

T6 - 10

15/07/2006

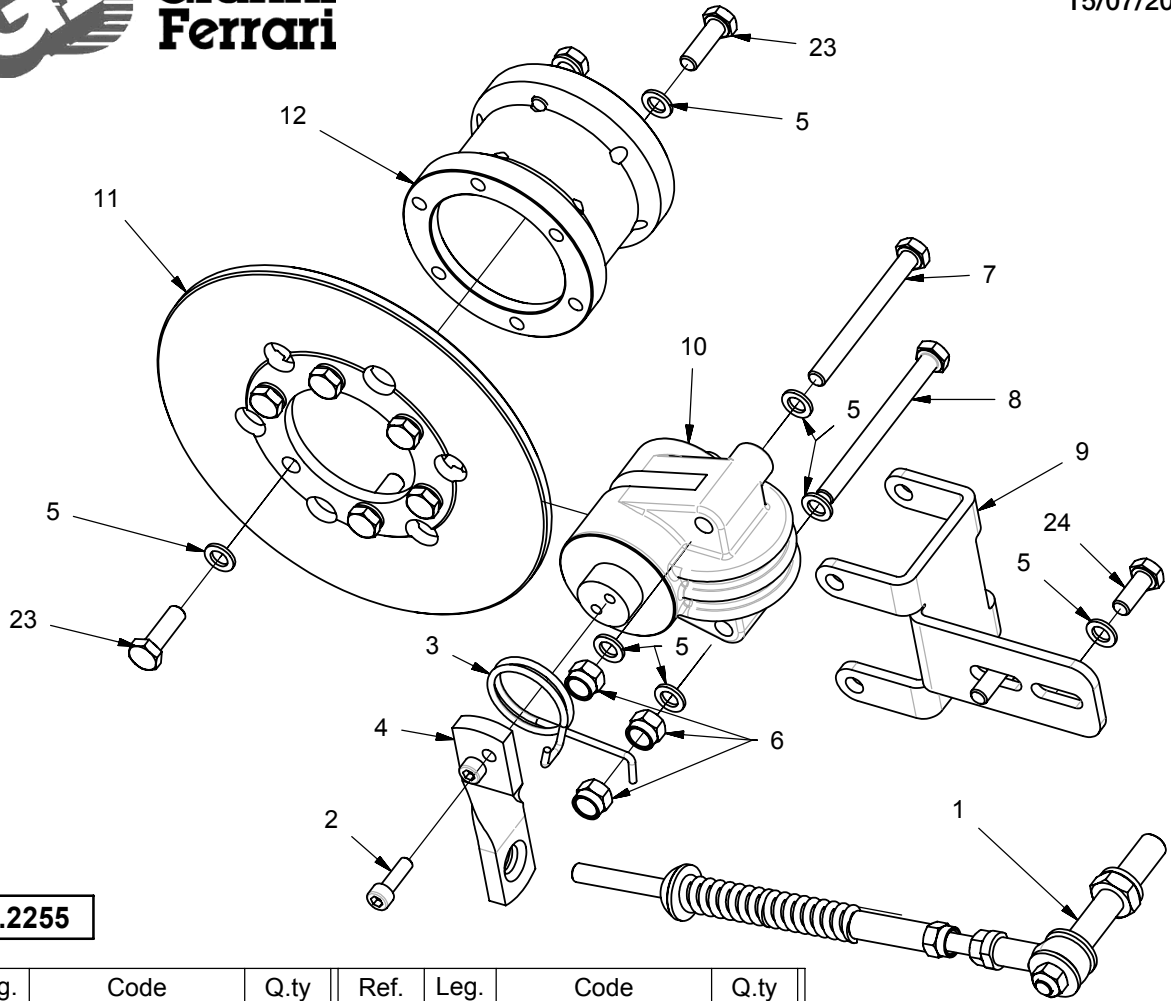

01.90.00.2255

Ref.	Leg.	Code	Q.ty	Ref.	Leg.	Code	Q.ty
7		00.92.05.0200	1	24		00.92.05.1070	2
6		00.26.04.0060	3	23		00.92.05.1080	12
5		00.68.01.0030	18	12		01.40.00.3440	1
4		01.50.01.0280	1	11		01.40.00.3450	1
3		00.47.00.0290	1	10		00.34.01.0050	1
2		00.90.04.0080	2	9		01.50.01.0410	1
1		01.90.00.2190	1	8		00.92.05.0220	1

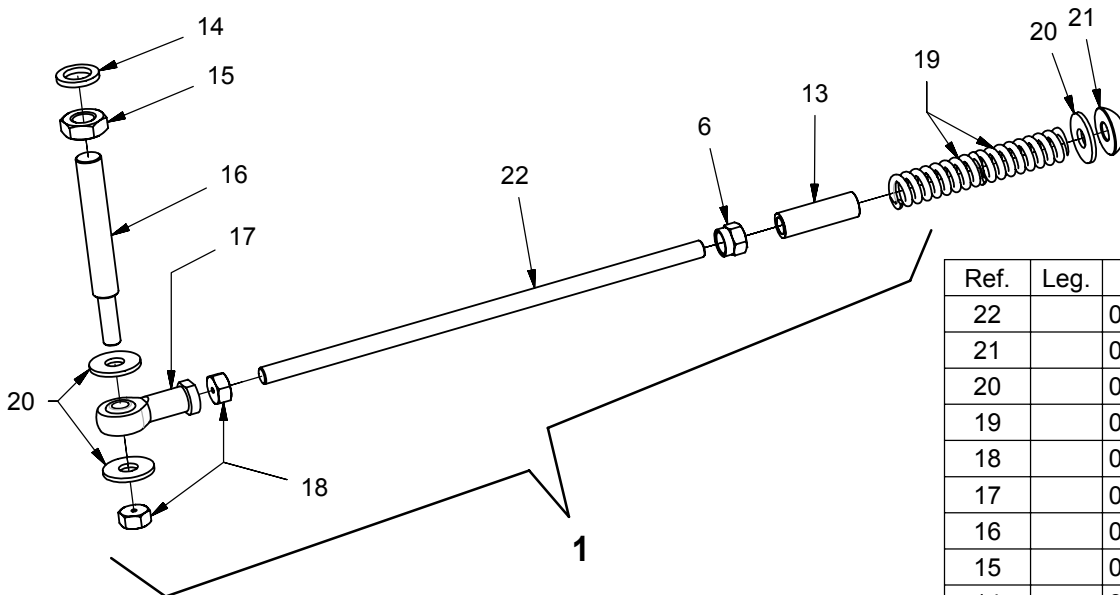

01.90.00.2190

Ref.	Leg.	Code	Q.ty
22		01.40.00.3740	1
21		01.20.00.0030	1
20		00.68.02.0050	3
19		00.47.00.0101	2
18		00.26.02.0060	2
17		00.78.01.0011	1
16		01.40.00.3750	1
15		00.26.03.0090	1
14		00.68.01.0050	1
13		01.40.00.2790	1
6		00.26.04.0060	1



Gianni Ferrari

T6 - 11

15/07/2006

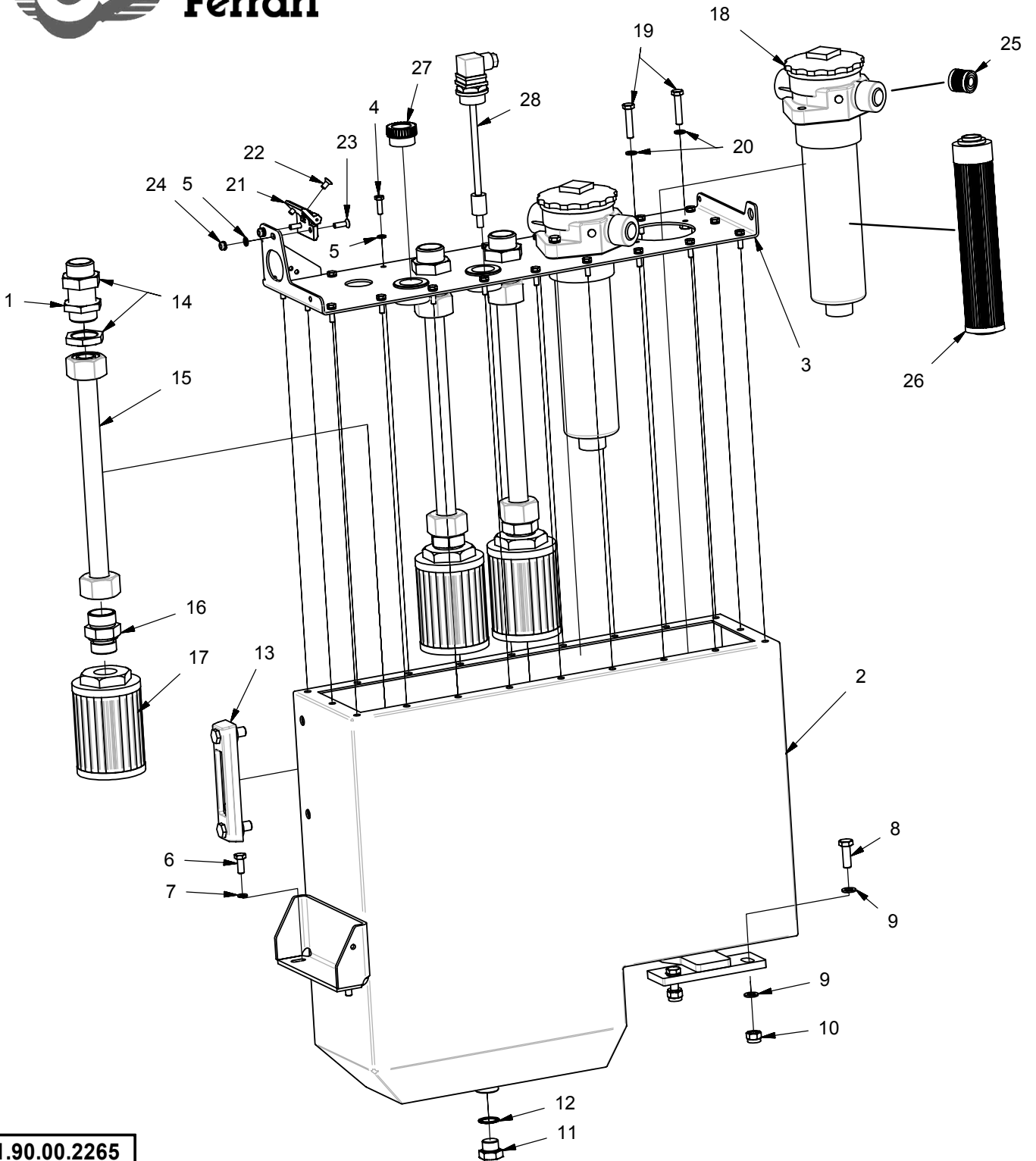

01.90.00.2265

Ref.	Leg.	Code	Q.ty	Ref.	Leg.	Code	Q.ty	Ref.	Leg.	Code	Q.ty
10		00.26.04.0070	2	19		00.92.05.0120	4	28		00.40.00.2160	1
9		00.68.01.0040	4	18		00.32.03.0150	2	27		00.85.03.0015	1
8		00.92.06.1080	2	17		00.32.03.0140	3	26		00.32.03.0160	1
7		00.68.03.0030	2	16		00.41.00.2807	3	25		00.32.03.0161	1
6		00.92.05.1070	2	15		00.41.00.2670	3	24		00.26.04.0040	2
5		00.68.01.0020	22	14		00.41.00.2798	3	23		00.95.04.0060	2
4		00.92.03.1070	20	13		00.75.00.0140	1	22		00.95.04.0020	2
3		00.75.00.0133	1	12		00.41.00.0071	1	21		00.99.00.0240	1
2		00.75.00.0130	1	11		00.85.02.0004	1	20		00.68.01.0030	4
1		00.41.00.3149	3								



**Gianni
Ferrari**

T6 - 12

30/06/2006

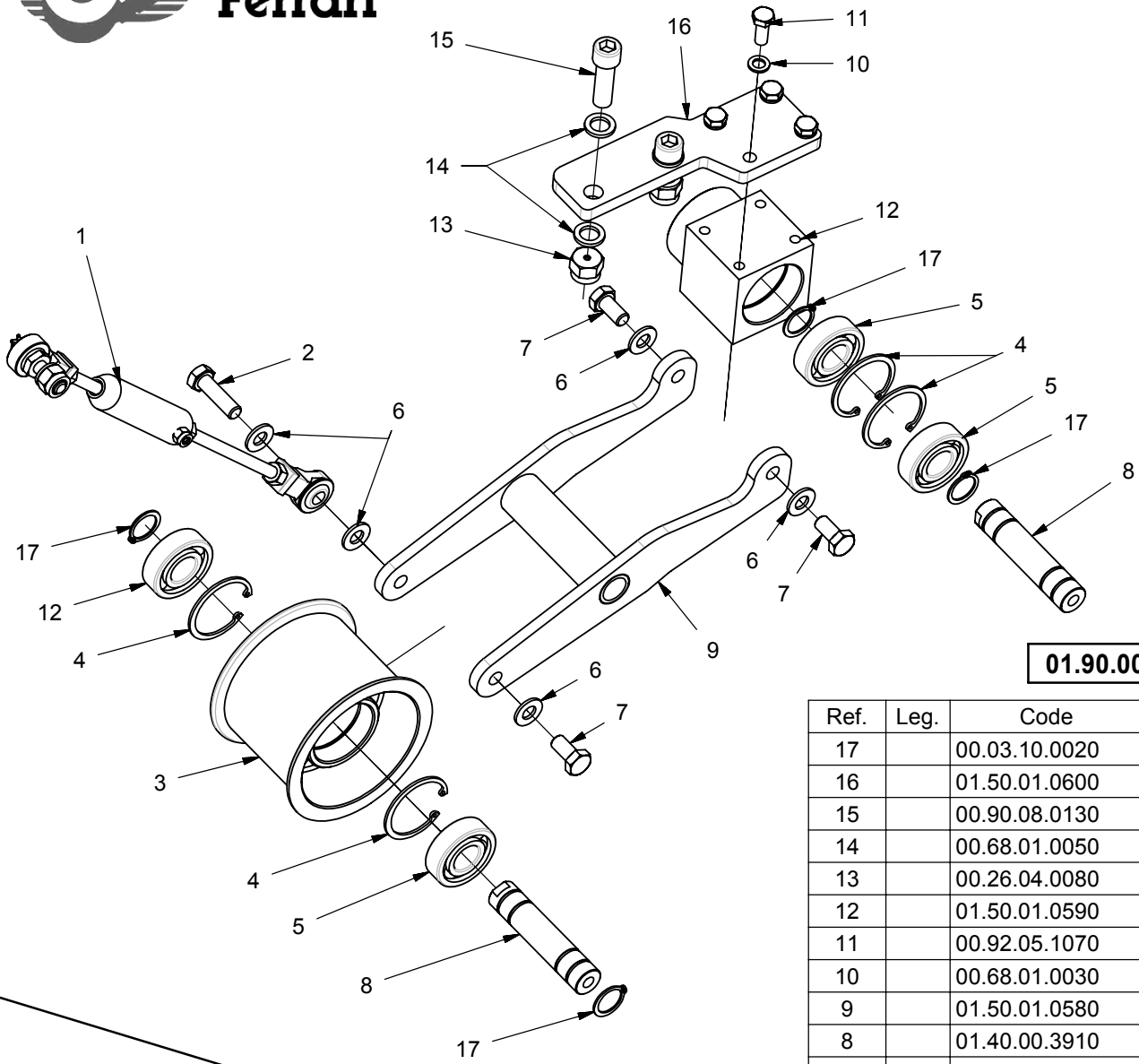

01.90.00.2256

Ref.	Leg.	Code	Q.ty
17		00.03.10.0020	4
16		01.50.01.0600	1
15		00.90.08.0130	2
14		00.68.01.0050	4
13		00.26.04.0080	2
12		01.50.01.0590	1
11		00.92.05.1070	4
10		00.68.01.0030	4
9		01.50.01.0580	1
8		01.40.00.3910	2
7		00.92.06.1040	3
6		00.68.01.0040	5
5		00.22.00.0230	4
4		00.03.01.0047	4
3		00.61.00.0670	1
2		00.92.06.1090	1
1		01.90.00.2180	1

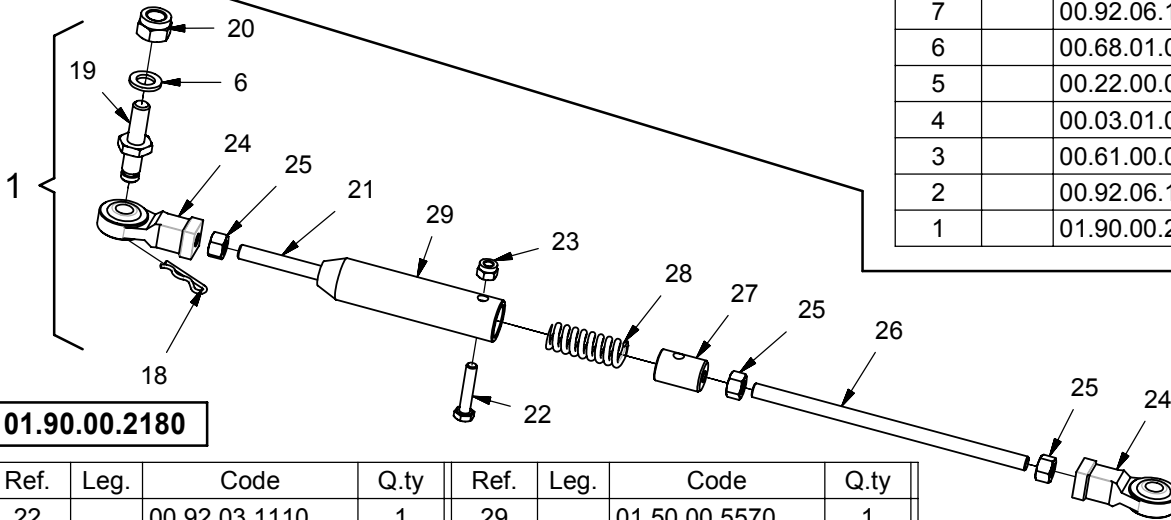

01.90.00.2180

Ref.	Leg.	Code	Q.ty	Ref.	Leg.	Code	Q.ty
22		00.92.03.1110	1	29		01.50.00.5570	1
21		00.90.06.0300	1	28		00.47.00.0101	1
20		00.26.04.0070	1	27		01.40.00.3730	1
19		01.40.00.4200	1	26		01.40.00.3720	1
18		00.18.00.1011	1	25		00.26.01.0060	3
6		00.68.01.0040	1	24		00.78.01.0112	2
				23		00.26.05.0040	1

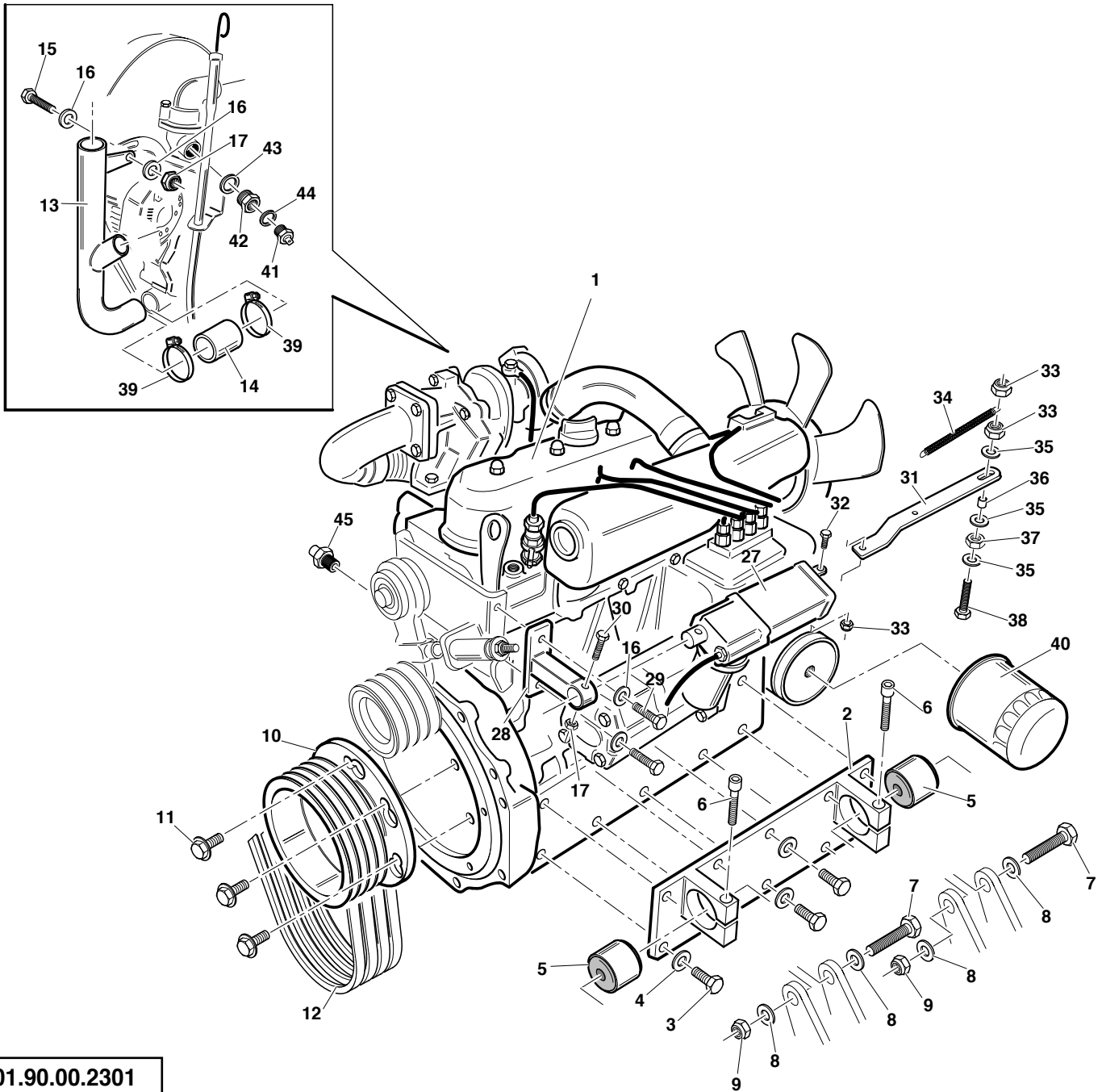
01.90.00.2301

Ref.	Leg.	Code	Q.ty	Ref.	Leg.	Code	Q.ty	Ref.	Leg.	Code	Q.ty
1		00.54.01.0070	1	13		01.50.01.1210	1	34		00.47.00.0040	1
2		01.50.00.8810	2	14		00.89.04.0035	0,1	35		00.68.03.0030	3
3		00.92.07.3050	18	15		00.92.05.0120	1	36		01.40.00.1220	1
4		00.68.04.0120	18	16		00.68.02.0050	3	37		00.26.04.0040	1
5		01.40.00.4440	4	17		00.26.04.0060	2	38		00.92.04.3130	1
6		00.90.07.0140	4	27		00.40.00.2060	1	39		00.29.00.0040	2
7		00.92.07.0210	4	28		01.50.01.1390	1	40		00.32.03.0110	1
8		00.68.01.0050	8	29		00.92.05.1070	2	41		00.40.00.0571	1
9		00.26.04.0080	4	30		00.92.05.0120	1	42		00.41.00.0914	1
10		00.61.00.0630	1	31		01.50.01.1400	1	43		00.41.00.0071	1
11		00.92.07.0052	6	32		00.92.03.0090	1	44		00.41.00.0070	1
12		00.17.01.0040	4	33		00.26.04.0040	2	45		00.55.01.0120	1



**Gianni
Ferrari**

T6-14

30/06/2006

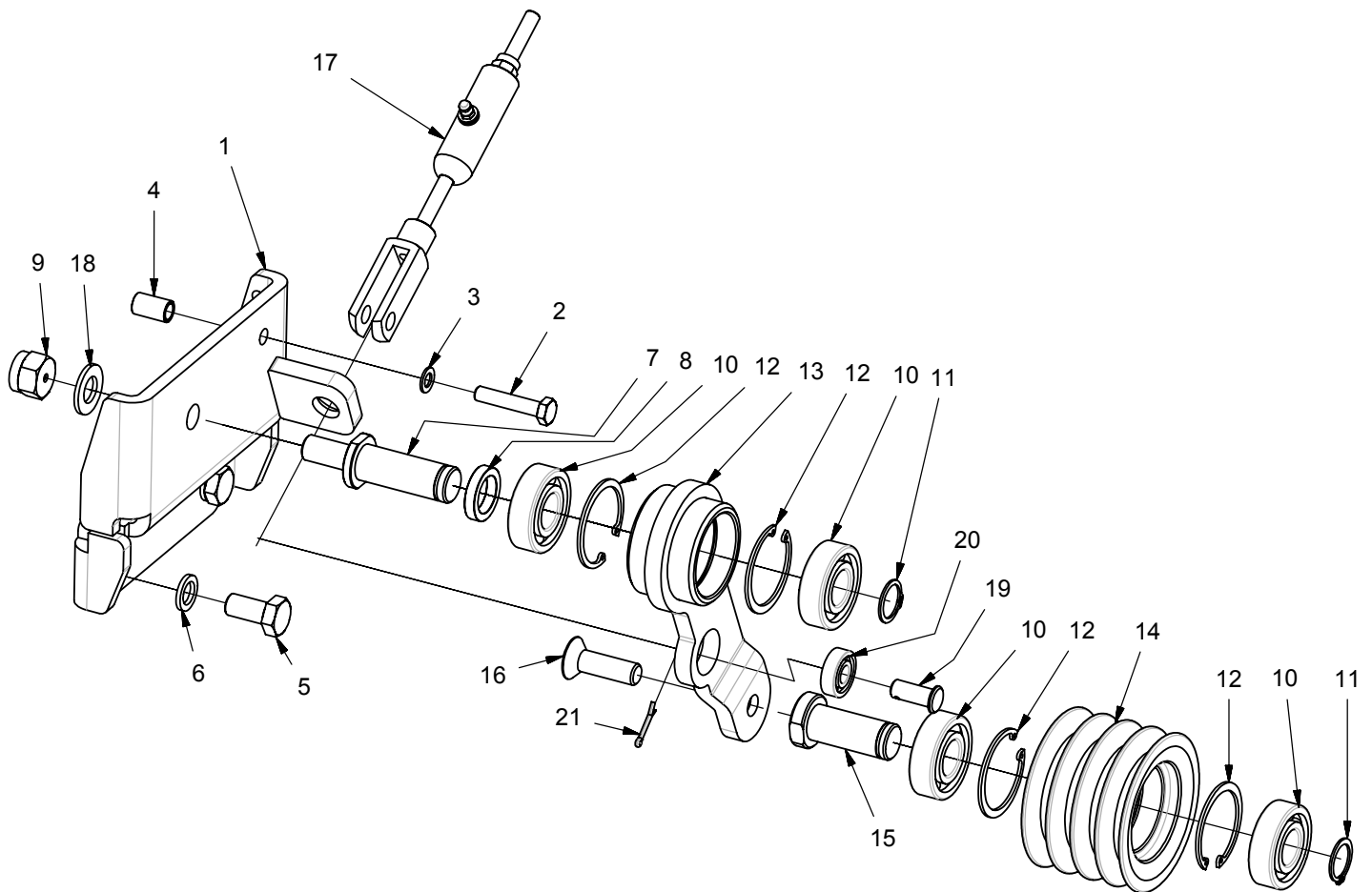

01.90.00.2302

Ref.	Leg.	Code	Q.ty	Ref.	Leg.	Code	Q.ty	Ref.	Leg.	Code	Q.ty
7		01.40.00.3930	1	14		00.61.00.0660	1	21		00.18.04.0052	1
6		00.68.01.0050	2	13		01.50.01.0610	1	20		00.22.00.0111	1
5		00.92.07.3050	2	12		00.03.01.0047	4	19		00.33.03.0022	1
4		01.40.00.0490	1	11		00.03.10.0020	2	18		00.68.01.0060	1
3		00.68.02.0050	1	10		00.22.00.0230	4	17		01.90.00.2185	1
2		00.92.05.0120	1	9		00.26.04.0090	1	16		00.95.07.0060	1
1		01.50.01.0640	1	8		01.40.00.4010	1	15		01.40.00.4020	1

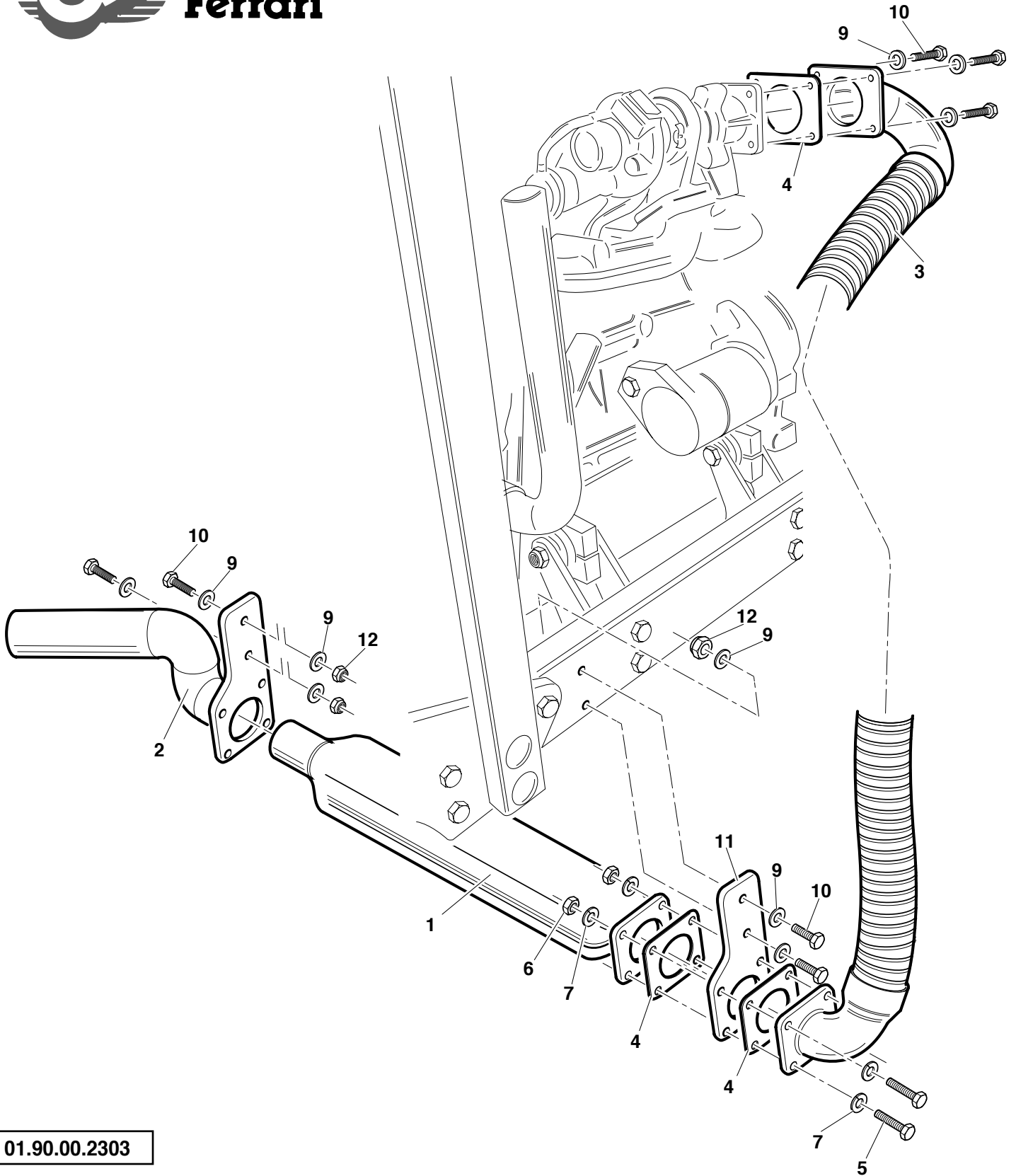
01.90.00.2303

Ref.	Leg.	Code	Q.ty	Ref.	Leg.	Code	Q.ty
1		00.46.00.0060	1	7		00.68.04.0070	8
2		01.50.01.1280	1	9		00.68.01.0030	12
3		01.50.01.0710	1	10		00.92.05.0100	8
4		00.55.01.0770	3	11		01.50.01.0310	1
5		00.92.05.0120	4	12		00.26.04.0060	4
6		00.26.02.0060	4				

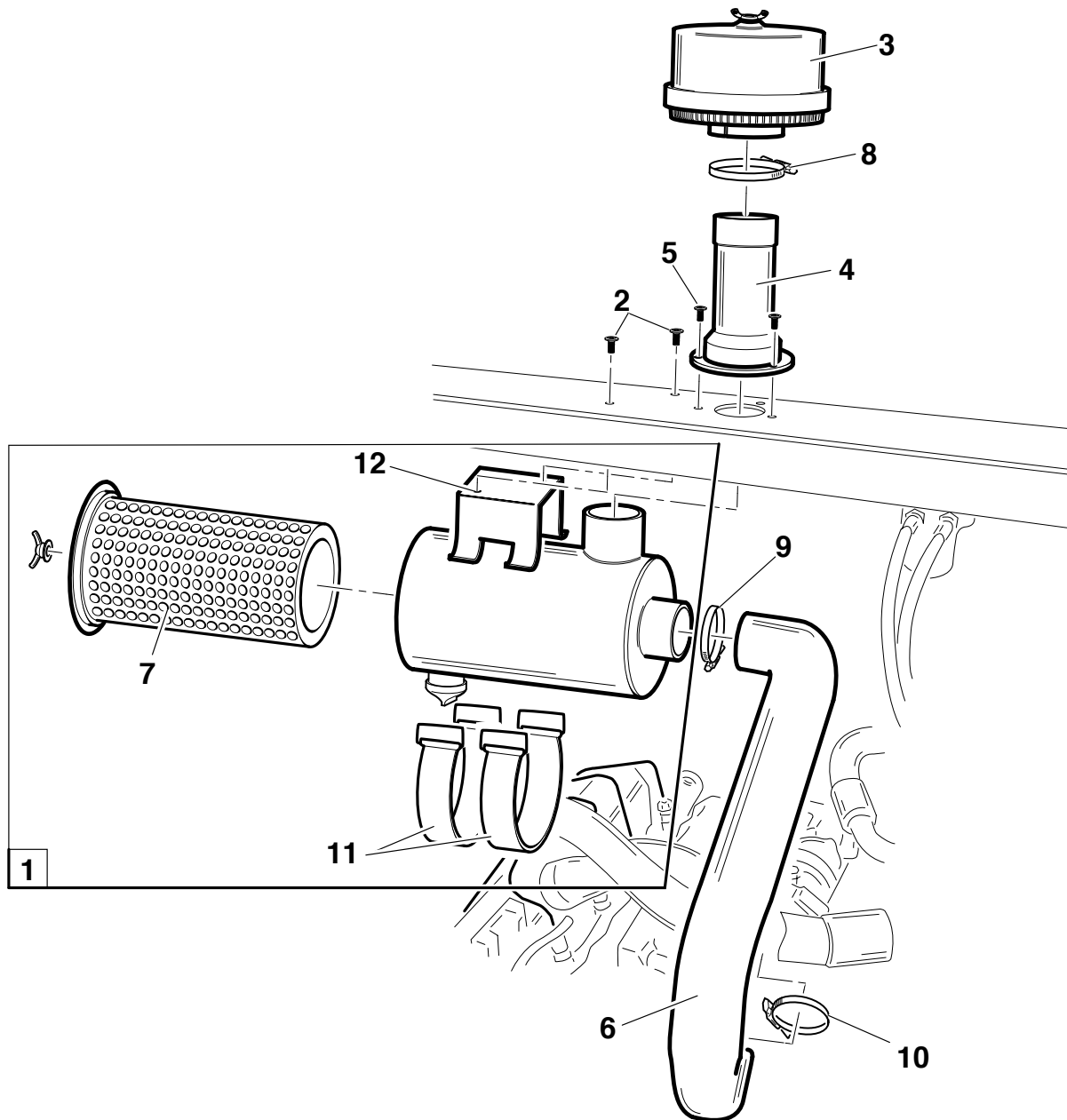
01.90.00.2304

Ref.	Leg.	Code	Q.ty	Ref.	Leg.	Code	Q.ty
1		00.32.03.0120	1	7		00.32.03.0130	1
2		00.90.06.3060	2	8		00.29.02.1075	1
3		00.32.03.0170	1	9		00.29.02.1080	1
4		01.50.01.1290	1	10		00.29.02.1055	1
5		00.90.04.3070	3	11		00.32.03.0121	2
6		00.07.07.0180	1	12		00.32.03.0122	1

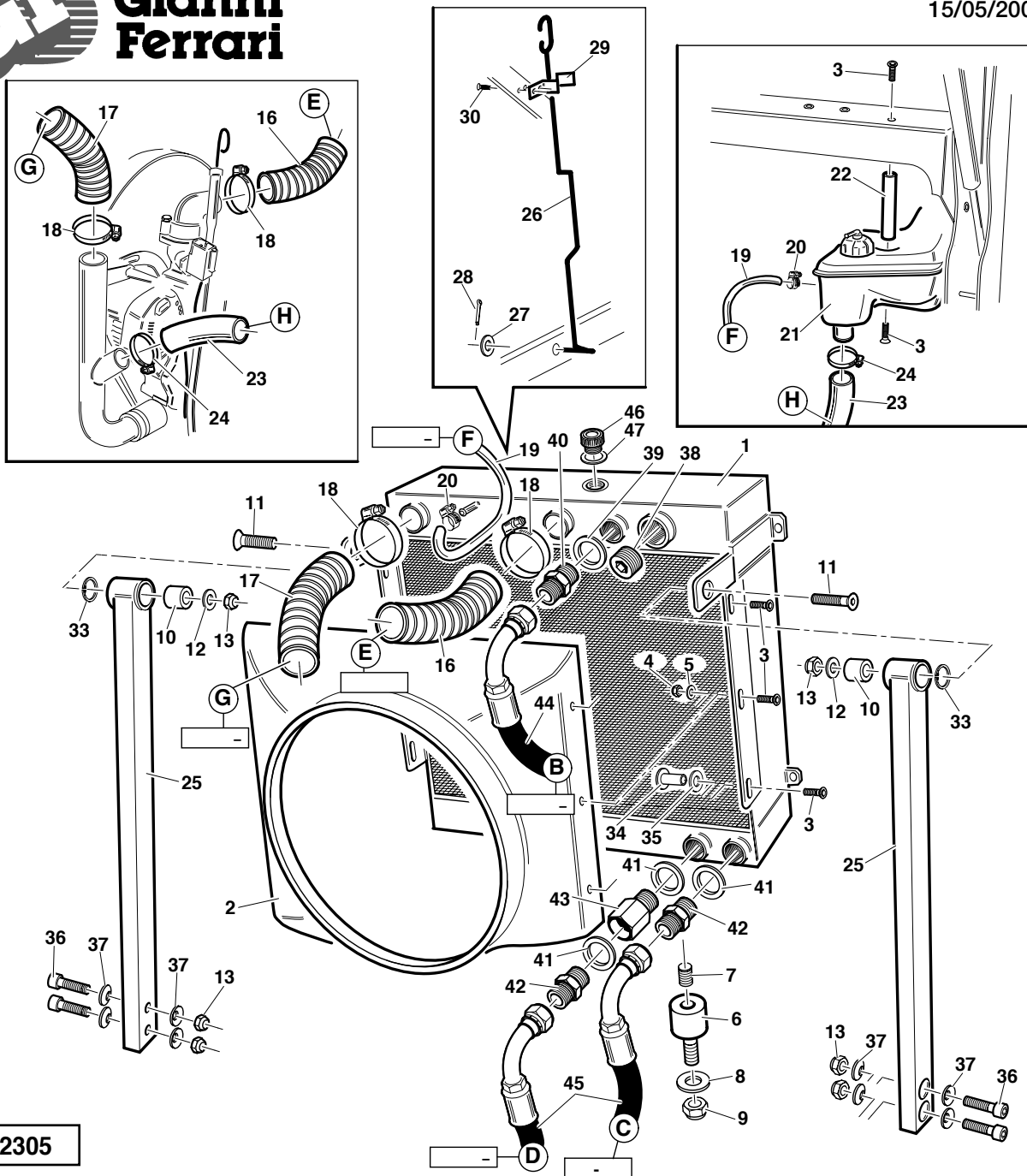
01.90.00.2305

Ref.	Leg.	Code	Q.ty	Ref.	Leg.	Code	Q.ty	Ref.	Leg.	Code	Q.ty
1		00.54.10.0070	1	17		00.89.08.0035	0,40	34		00.66.01.0080	1
2		01.30.00.0630	1	18		00.29.02.0060	4	35		00.68.02.0050	1
3		00.90.06.3080	7	19		00.89.02.0000	1,3	36		00.92.07.0090	4
4		00.26.04.0060	6	20		00.29.03.0010	2	37		00.68.05.0010	8
5		00.68.01.0030	6	21		00.75.00.0150	1	38		00.85.00.0090	1
6		00.74.01.0090	2	22		01.50.01.0900	1	39		00.41.00.0074	1
7		00.96.06.0100	2	23		00.89.04.0025	0,60	40		00.41.00.0116	1
8		00.68.02.0070	2	24		00.29.02.0027	2	41		00.41.00.0073	3
9		00.26.04.0070	2	25		01.50.01.0690	2	42		00.41.00.0823	2
10		00.74.05.3234	2	26		01.50.00.0490	1	43		00.41.00.0934	1
11		00.90.08.3170	2	27		00.68.01.0040	1	44		00.41.00.2810	1
12		00.68.01.0050	2	28		00.18.04.0021	1	45		00.41.00.2400	2
13		00.26.04.0080	6	29		00.47.00.0420	1	46		00.85.02.0081	1
14		00.85.00.0090	1	30		00.66.06.0031	2	47		00.41.00.0210	1
16		00.89.08.0035	0,45	33		00.03.11.0032	2				



Gianni Ferrari

T6 - 18

15/07/2005

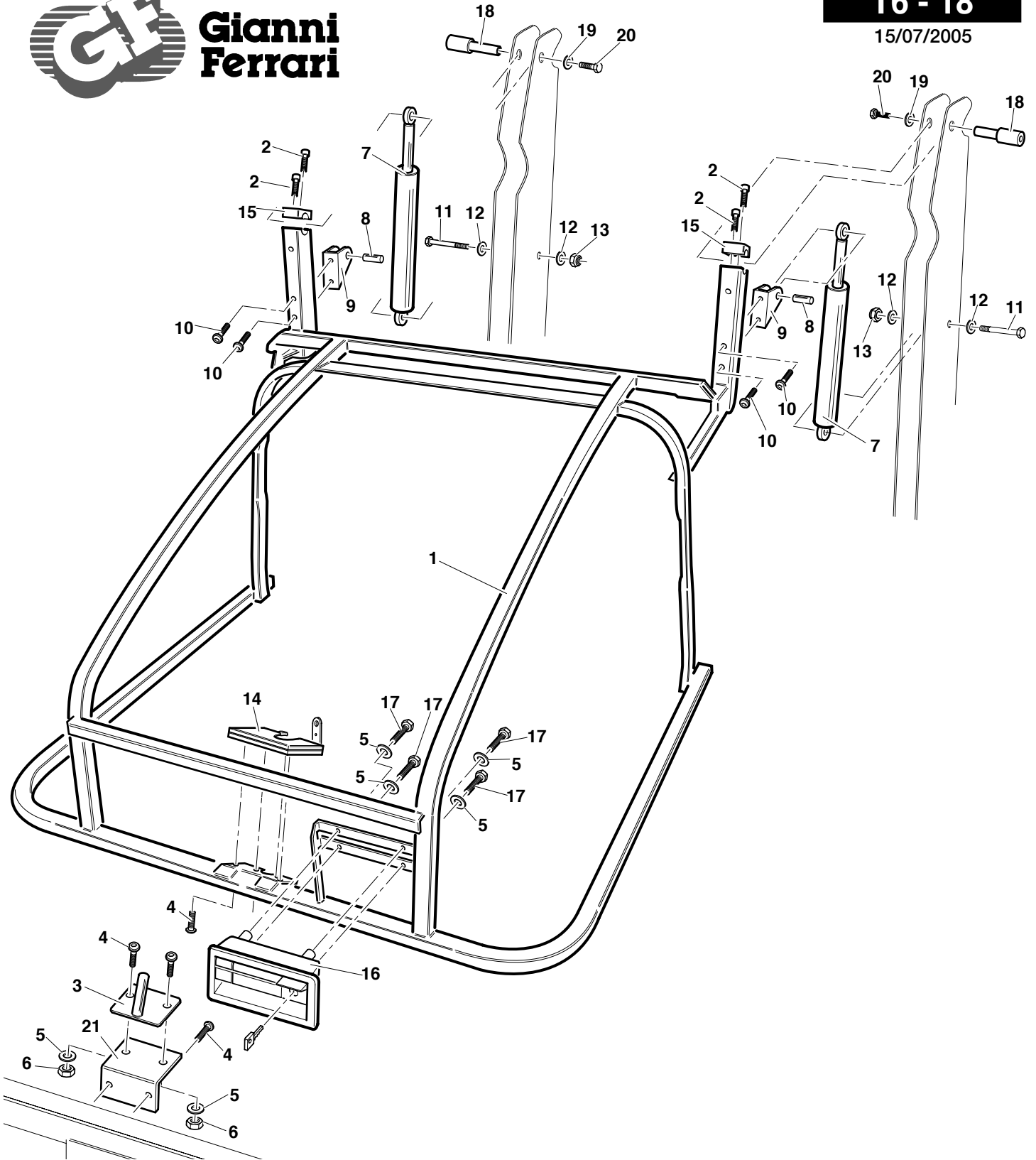

01.90.00.2306

Ref.	Leg.	Code	Q.ty	Ref.	Leg.	Code	Q.ty	Ref.	Leg.	Code	Q.ty
1		01.50.01.1120	1	8		01.40.00.4110	2	15		01.50.01.1550	1
2		00.90.04.0080	4	9		01.50.01.1530	2	16		00.44.01.0040	1
3		01.50.01.1520	1	10		00.90.06.3080	4	17		00.92.03.1070	4
4		00.90.04.3070	6	11		00.92.06.0170	2	18		01.40.00.3050	2
5		00.68.01.0020	6	12		00.68.01.0050	4	19		00.68.08.0170	2
6		00.26.04.0040	2	13		00.26.04.0070	2	20		00.92.05.1070	2
7		00.49.25.1500	2	14		00.99.00.0280	1	21		01.50.01.1160	1

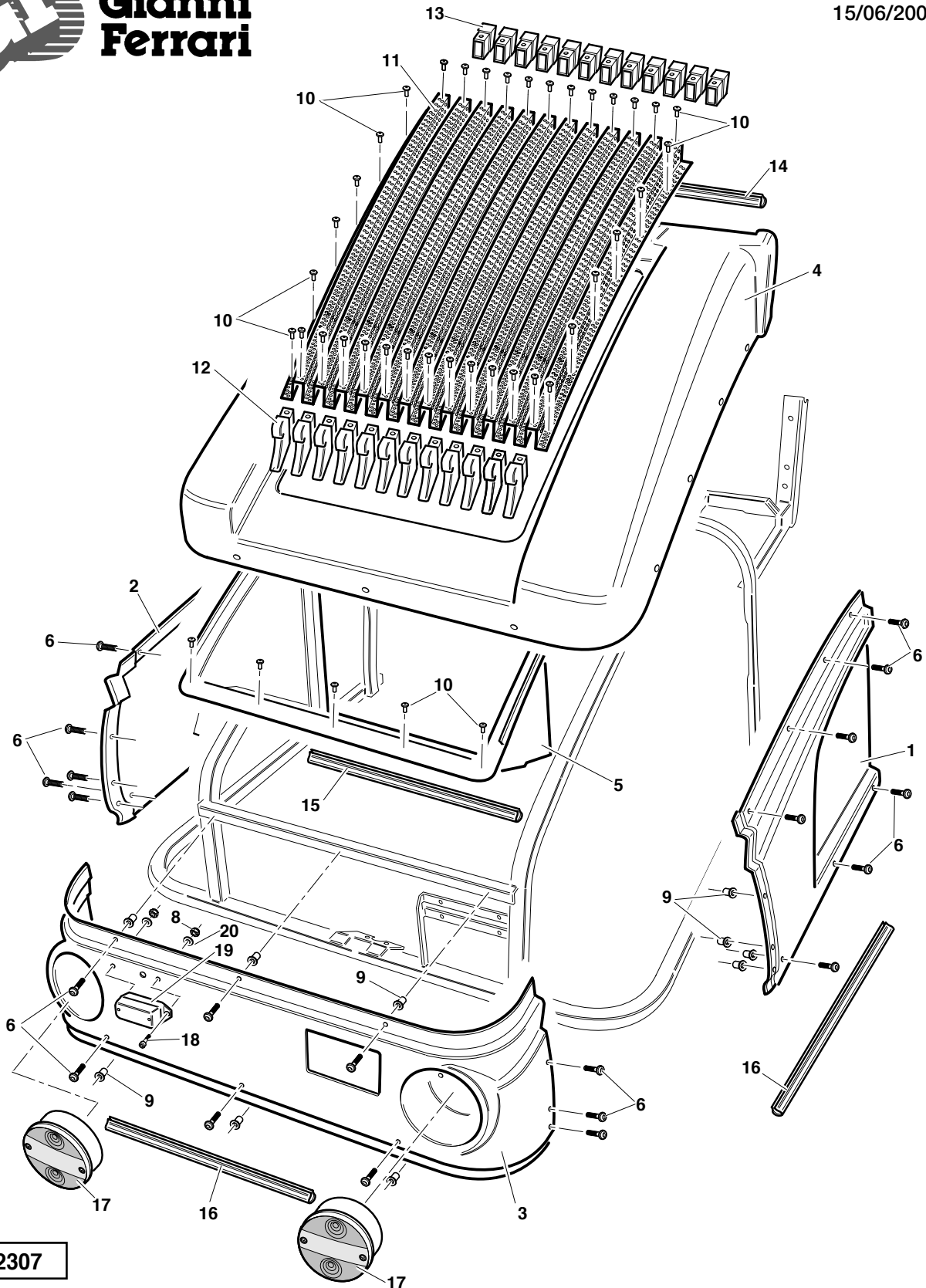
01.90.00.2307

Ref.	Leg.	Code	Q.ty	Ref.	Leg.	Code	Q.ty	Ref.	Leg.	Code	Q.ty
1		01.30.00.0700	1	8		00.26.04.0040	6	15		00.11.01.2000	1
2		01.30.00.0710	1	9		00.66.01.0060	26	16		00.11.01.2010	1
3		01.30.00.0720	1	10		00.66.06.0072	60	17		00.40.00.2150	2
4		01.30.00.0730	1	11		01.50.01.1420	1	18		00.95.04.0060	2
5		01.30.00.0740	1	12		01.30.00.0650	11	19		00.40.00.2160	1
6		00.90.04.3100	26	13		01.30.00.0660	11	20		00.68.01.0020	2
7		00.68.03.0030	4	14		00.11.01.0000	1				

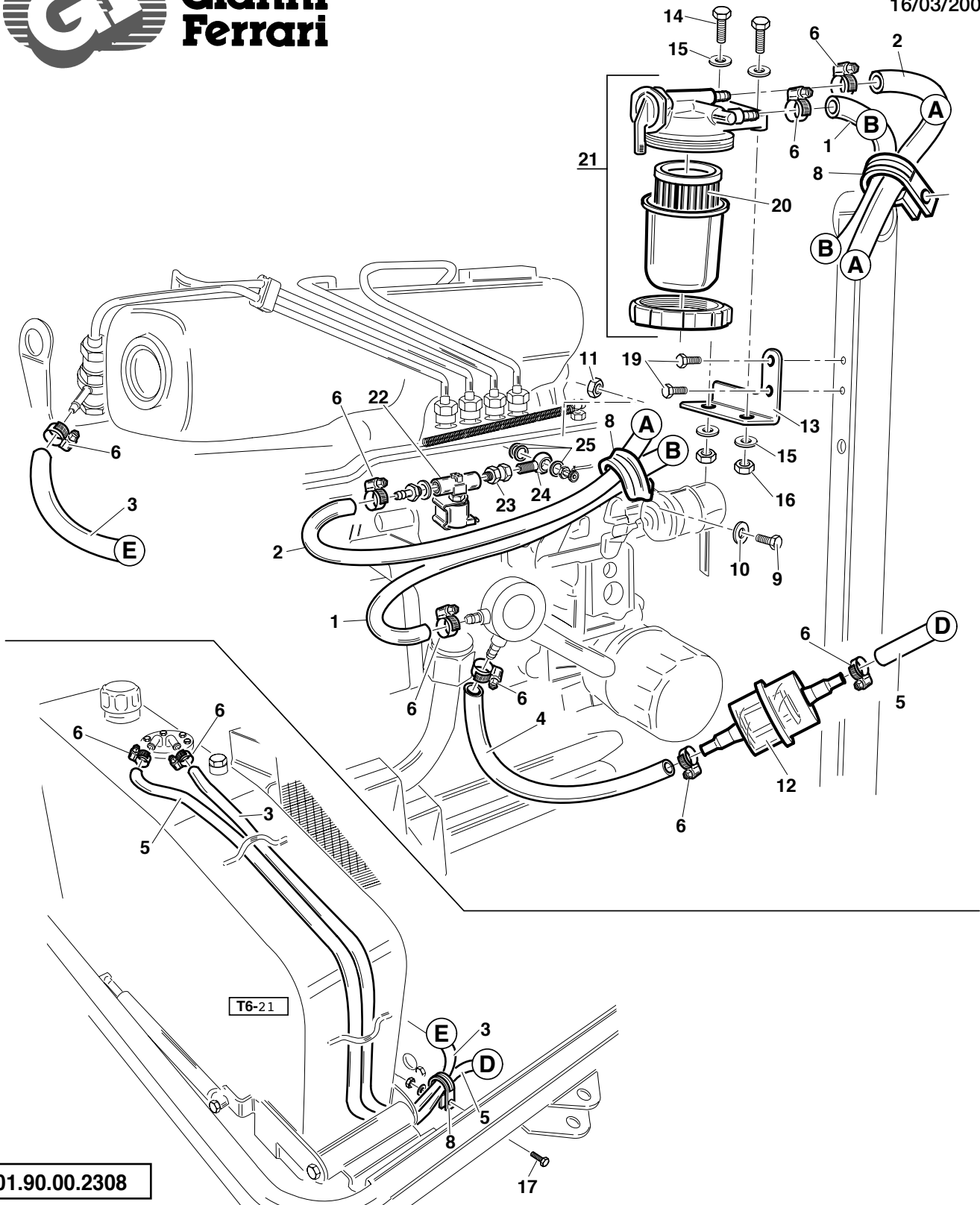
01.90.00.2308

Ref.	Leg.	Code	Q.ty	Ref.	Leg.	Code	Q.ty	Ref.	Leg.	Code	Q.ty
1		00.89.02.0000	0,60	10		00.68.01.0020	5	19		00.90.04.3030	2
2		00.89.02.0000	0,60	11		00.26.04.0040	5	20		00.32.03.0100	1
3		00.89.01.0000	3	12		00.32.00.0060	1	21		00.55.01.0750	1
4		00.89.02.0000	0,25	13		01.50.01.0930	1	22		00.41.00.3100	1
5		00.89.02.0000	2,5	14		00.92.05.0100	2	23		00.41.00.2821	1
6		00.29.02.0016	10	15		00.68.01.0030	4	24		00.41.00.3111	1
8		00.29.01.0099	8	16		00.26.04.0060	2	25		00.41.00.0212	3
9		00.92.03.1070	5	17		00.92.05.1010	2				



**Gianni
Ferrari**

T6 - 21

30/06/2005

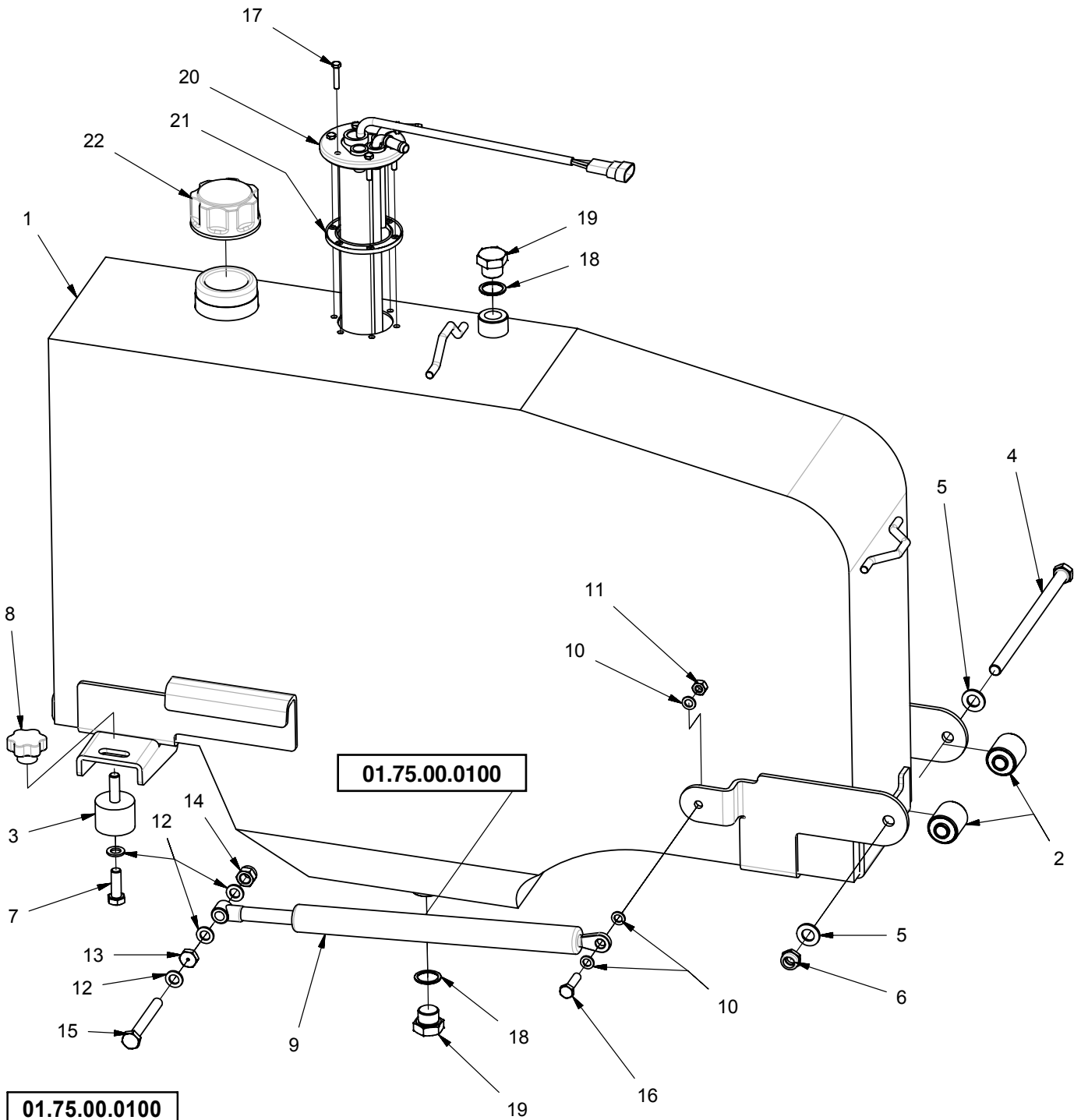

01.75.00.0100

Ref.	Leg.	Code	Q.ty	Ref.	Leg.	Code	Q.ty	Ref.	Leg.	Code	Q.ty
7		00.92.06.1080	1	14		00.26.04.0070	1	22		00.75.00.0102	1
6		00.26.04.0080	1	13		00.26.03.0080	1	21		00.07.01.0170	1
5		00.68.01.0050	2	12		00.68.01.0040	4	20		00.75.00.0101	1
4		00.92.07.0320	1	11		00.26.02.0060	1	19		00.85.02.0004	2
3		00.74.01.0090	1	10		00.68.01.0030	3	18		00.41.00.0071	2
2		00.74.05.3234	2	9		00.49.25.0800	1	17		00.92.02.0090	6
1		01.50.01.0940	1	8		00.45.00.0009	1	16		00.92.05.0100	1
								15		00.92.06.0180	1



**Gianni
Ferrari**

T6 - 22

30/06/2005

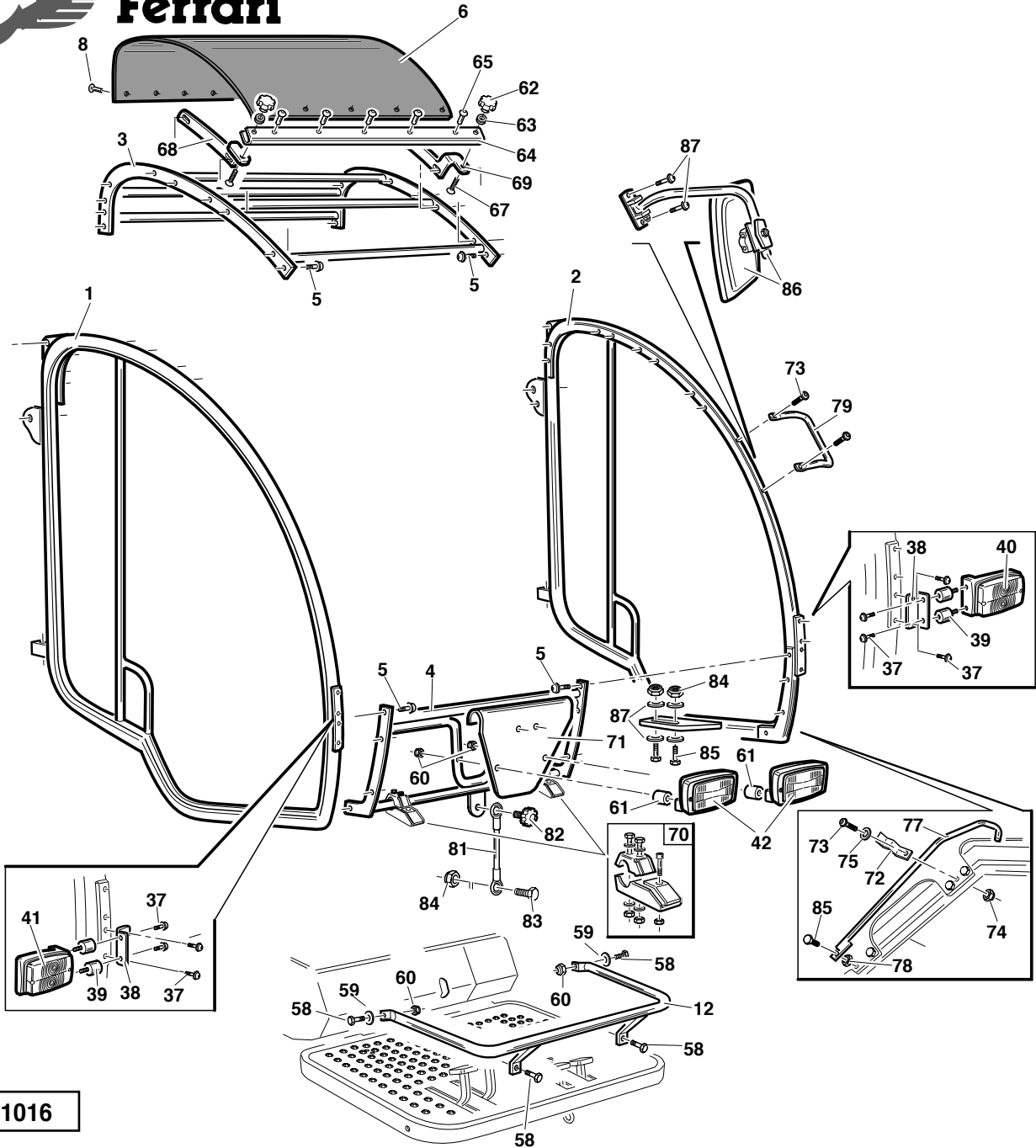

89.00.06.1016

Ref.	Leg.	Code	Q.ty	Ref.	Leg.	Code	Q.ty	Ref.	Leg.	Code	Q.ty
1		01.50.00.8350	1	58		00.92.03.0150	4	73		00.91.04.0090	1
2		01.50.00.8360	1	59		00.68.01.0020	4	74		00.26.04.0020	1
3		01.50.00.8370	1	60		00.26.04.0060	4	75		00.68.03.0010	1
4		01.50.00.8380	1	61		01.30.00.0620		77		01.50.01.1660	1
5		00.90.06.3060	22	62		00.45.00.0116	2	78		00.26.02.0080	1
6		01.29.00.0050	1,16	63		00.07.01.0038	2	79		01.50.01.1840	1
8		00.66.06.0071	8	64		01.50.01.0780	1	80		00.90.06.3080	2
12		01.50.00.8400	1	65		00.66.10.4013	5	81		01.50.01.1880	1
37		00.90.04.3030	8	67		00.90.06.3100	2	82		00.45.01.0127	1
38		01.50.00.8750	2	68		01.50.01.0760	1	83		00.92.06.0110	1
39		00.74.03.0050	4	69		01.50.01.0761	1	84		00.26.04.0070	5
40		00.40.00.0960	1	70		01.50.01.1720	2	85		00.92.06.1090	5
41		00.40.00.0970	1	71		01.50.01.0540	1	86		00.99.00.0290	1
42		00.40.00.0950	2	72		00.47.00.0420	1				

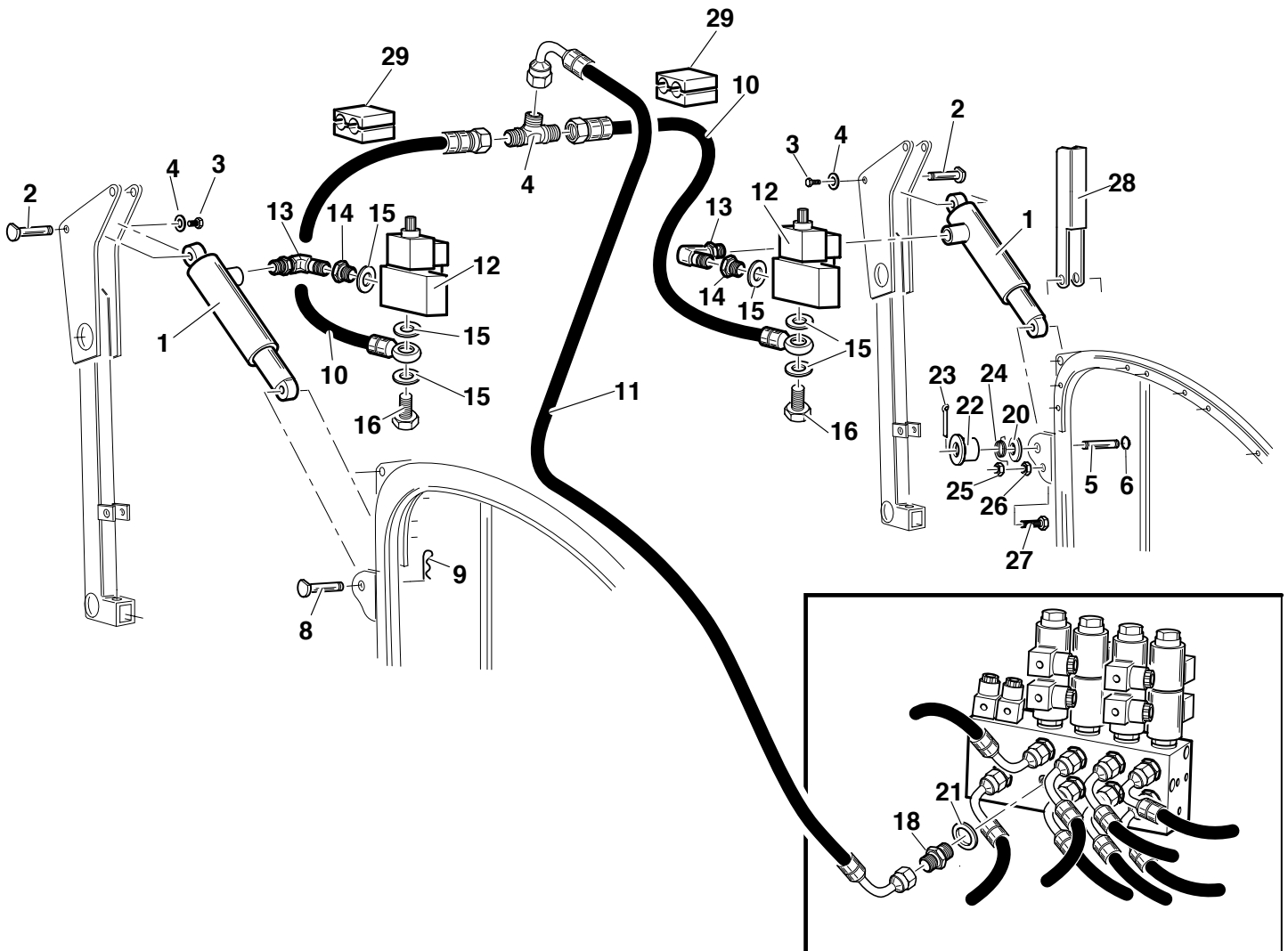
01.90.00.2346

Ref.	Leg.	Code	Q.ty	Ref.	Leg.	Code	Q.ty	Ref.	Leg.	Code	Q.ty
1		00.58.00.0160	2	12		00.41.00.2260	2	22		01.50.00.1250	1
2		01.50.00.2310	2	13		00.41.00.0874	2	23		00.18.04.0065	1
3		00.92.05.1040	2	14		00.41.00.2821	2	24		00.47.00.0440	1
4		00.68.08.0170	2	15		00.41.00.0060	8	25		00.26.04.0060	1
5		01.40.00.2690	1	16		00.41.00.0120	2	26		00.26.02.0060	1
6		00.03.10.0016	1	17		00.41.00.0901	1	27		00.92.05.0120	1
8		01.50.00.2950	1	18		00.41.00.0452	1	28		01.50.01.1340	1
9		00.18.00.1010	1	19		00.38.03.0040	0,8	29		00.41.00.0440	2
10		00.41.00.2840	2	20		00.48.00.0183	1				
11		00.41.00.2850	1	21		00.41.00.0070	1				

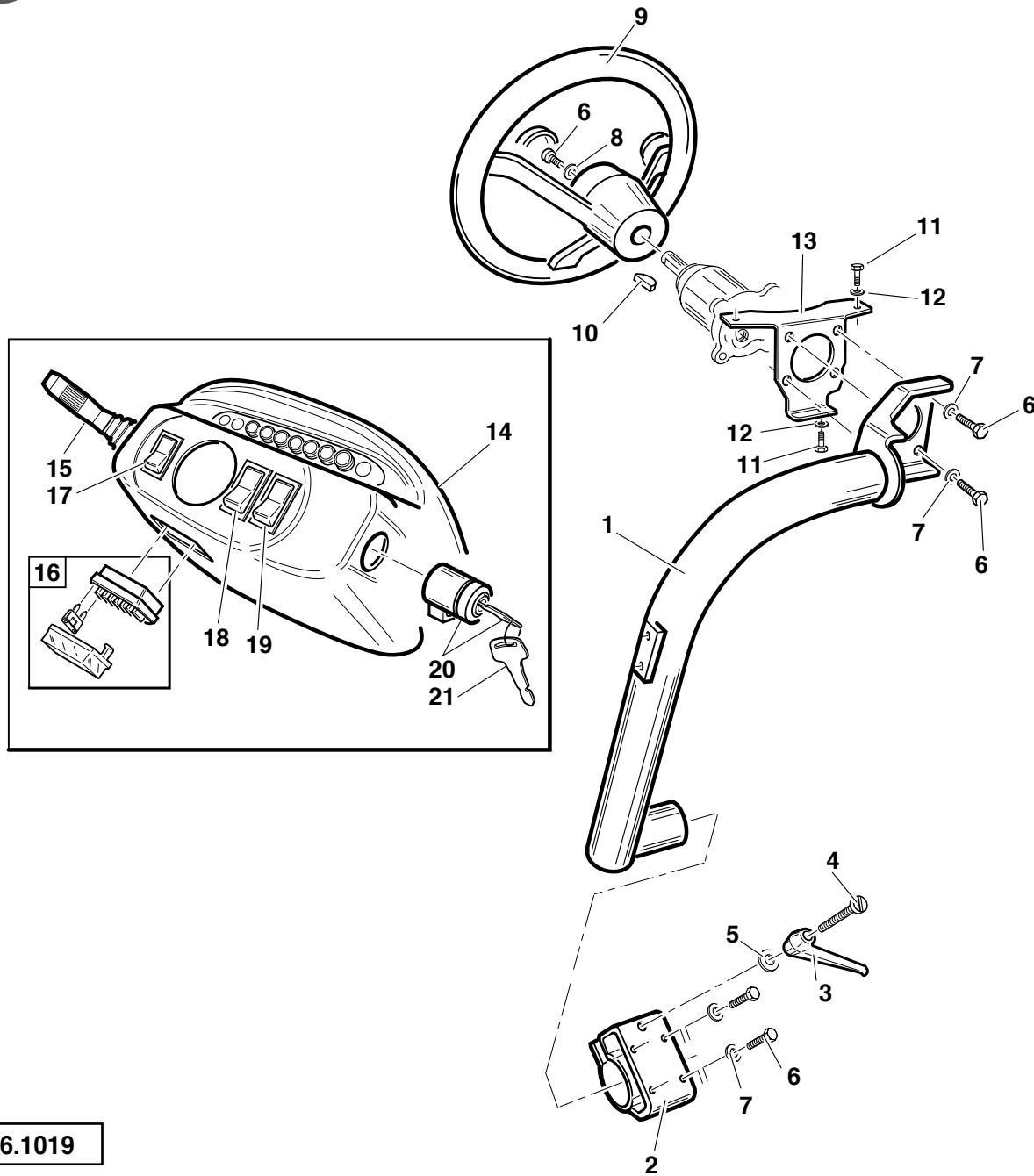
89.00.06.1019

Ref.	Leg.	Code	Q.ty	Ref.	Leg.	Code	Q.ty
1		01.50.01.0850	1	14		01.30.00.0790	1
2		01.50.00.5640	1	15		00.40.00.0880	1
3		00.44.02.0070	1	16		00.40.00.2220	1
4		00.98.00.0010	0,12	17		00.40.00.2231	1
5		00.68.01.0030	1	18		00.40.00.2232	1
6		00.92.05.1070	8	19		00.40.00.2233	1
7		00.68.01.0030	8	20		00.55.01.0091	1
8		00.68.02.0050	1	21		00.40.00.0091	1
9		00.25.03.0020	1				
10		00.43.05.0090	1				
11		00.91.05.1070	3				
12		00.68.01.0010	3				
13		01.50.00.5771	1				

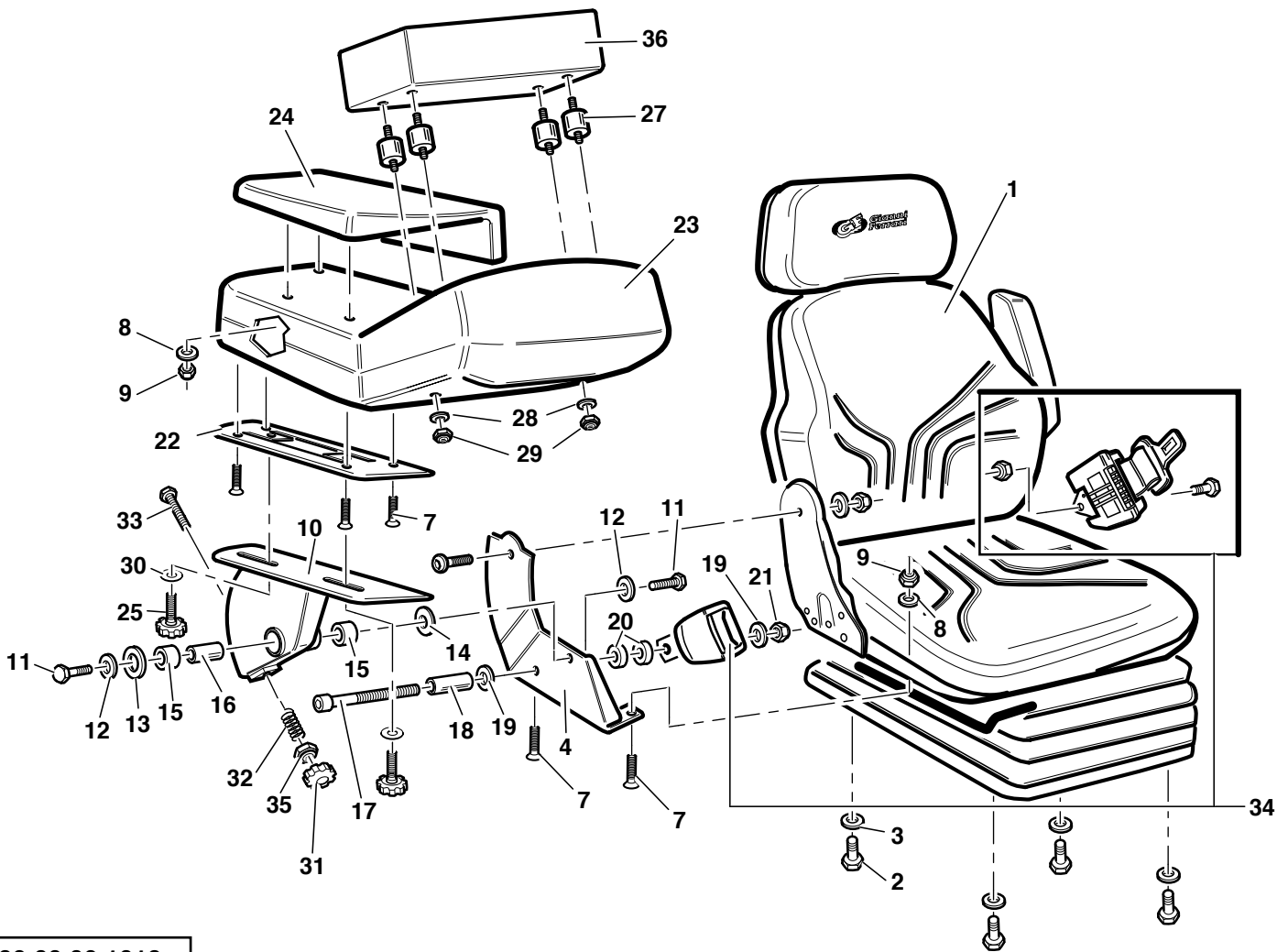
89.00.06.1018

Ref.	Leg.	Code	Q.ty	Ref.	Leg.	Code	Q.ty
1		00.73.00.0030	1	19		00.68.01.0040	2
2		00.92.05.0130	4	20		01.40.00.2120	2
3		00.68.01.0030	4	21		00.26.04.0070	1
4		01.50.01.0970	1	22		01.50.01.1410	1
5		00.26.04.0060	1	23		01.30.00.0670	1
6		00.68.02.0050	1	24		01.30.00.0680	1
7		00.95.04.0060	6	25		00.45.00.0009	2
8		00.68.01.0020	6	26		00.96.06.0100	2
9		00.26.04.0040	6	27		00.74.00.2015	4
10		01.50.01.0980	1	28		00.68.01.0010	4
11		00.92.08.1060	2	29		00.26.04.0030	4
12		00.68.01.0060	2	30		00.68.02.0070	2
13		01.40.00.1050	1	31		00.45.00.0008	1
14		00.48.00.0186	1	32		00.47.00.0450	1
15		00.10.20.0015	2	33		00.92.05.0180	1
16		01.40.00.4090	1	34		00.73.00.0035	1
17		00.90.07.0230	1	35		00.26.02.0060	1
18		01.40.00.4100	1	36		00.40.00.2120	1



**Gianni
Ferrari**

T6 - 27

15/07/2006

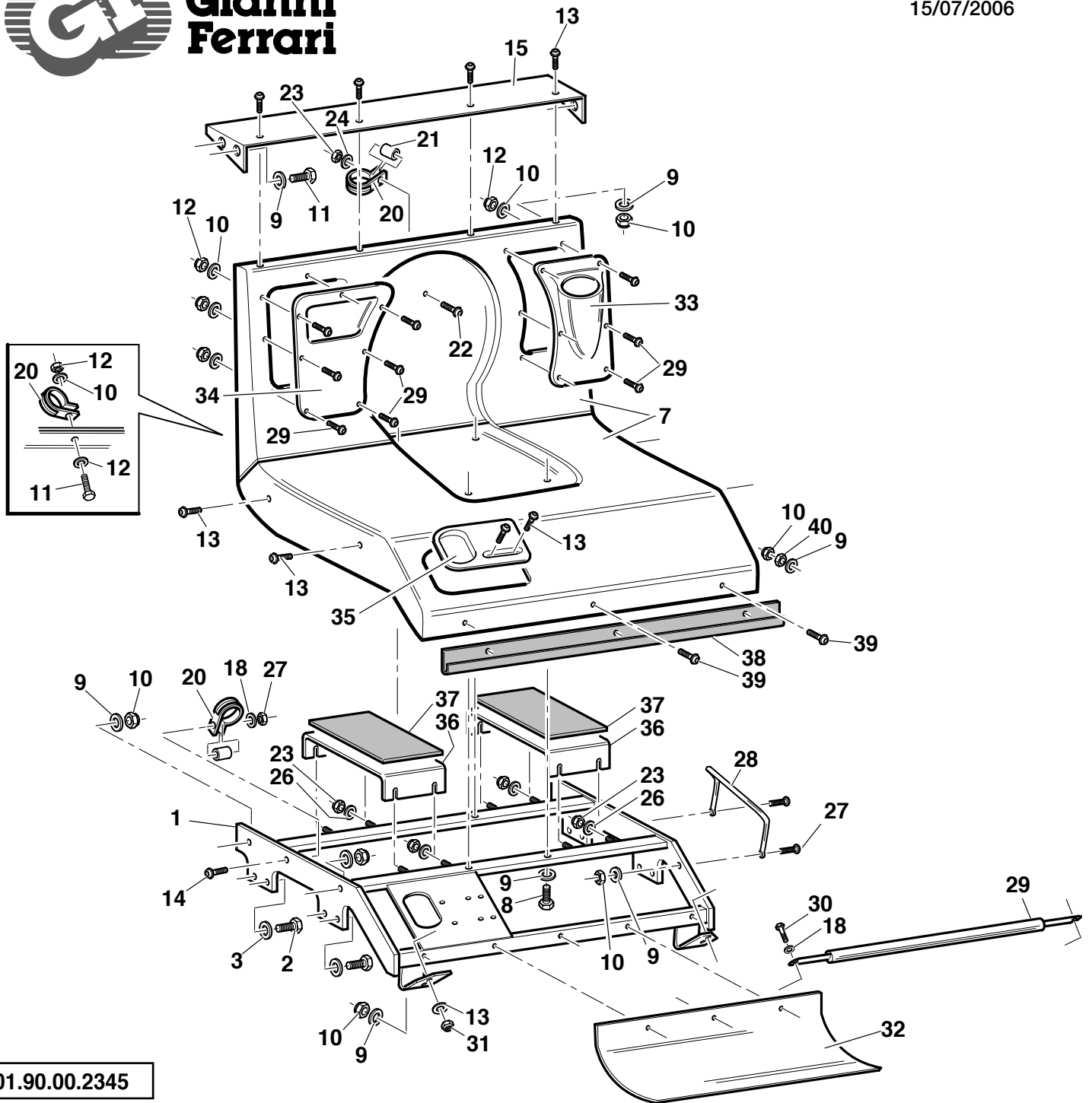

01.90.00.2345

Ref.	Leg.	Code	Q.ty	Ref.	Leg.	Code	Q.ty	Ref.	Leg.	Code	Q.ty
1		01.50.01.0820	1	14		00.90.04.3150	5	28		01.50.01.1840	1
2		00.92.06.1040	7	15		01.50.01.1490	1	29		01.50.01.1930	1
3		00.68.01.0040	8	17		00.92.03.0150	8	30		00.92.03.0090	2
4		00.92.06.0100	4	18		00.68.01.0020	2	31		00.26.04.0040	2
5		00.68.02.0070	8	19		00.92.06.0090	1	32		01.29.00.0110	1
6		00.26.04.0070	4	20		00.29.01.0099	6	33		01.30.00.0693	1
7		01.30.00.0690	1	21		01.40.00.2790	4	34		01.30.00.0694	1
8		00.92.03.0140	4	22		00.90.06.3170	2	35		01.30.00.0697	1
9		00.68.02.0030	17	23		00.26.04.0060	13	36		01.50.01.1505	2
10		00.26.04.0040	41	24		00.68.01.0030	5	37		00.07.05.0027	0,60
11		00.92.03.1070	10	25		00.90.06.3150	3	38		01.50.01.1492	1
12		00.68.03.0030	31	26		00.68.02.0050	11	39		00.90.04.3170	3
13		00.90.04.3070	4	27		00.90.04.3110	14	40		00.26.02.0040	3

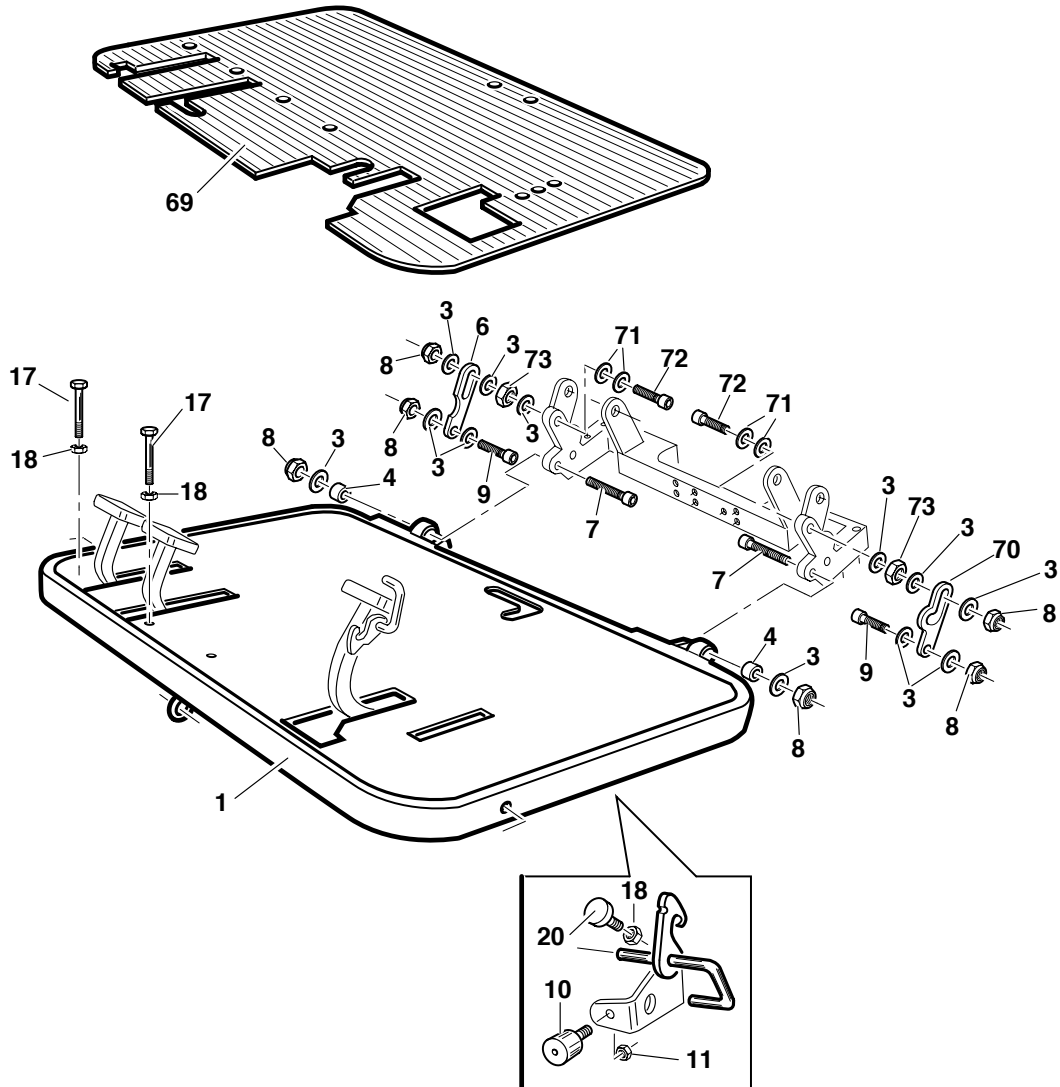
01.90.00.2351

Ref.	Leg.	Code	Q.ty	Ref.	Leg.	Code	Q.ty	Ref.	Leg.	Code	Q.ty
1		01.50.00.4920	1	9		00.90.08.0140	2	69		01.29.00.0090	1
3		00.68.01.0050	10	10		00.74.00.0030	2	70		01.50.01.1350	1
4		00.74.05.3234	2	11		00.26.02.0060	3	71		00.68.04.0120	4
6		01.50.00.4930	1	17		00.92.03.1120	1	72		00.90.08.0181	2
7		00.90.08.0211	2	18		00.26.02.0040	3	73		00.26.03.0090	2
8		00.26.04.0080	6	20		00.74.00.0017	1				

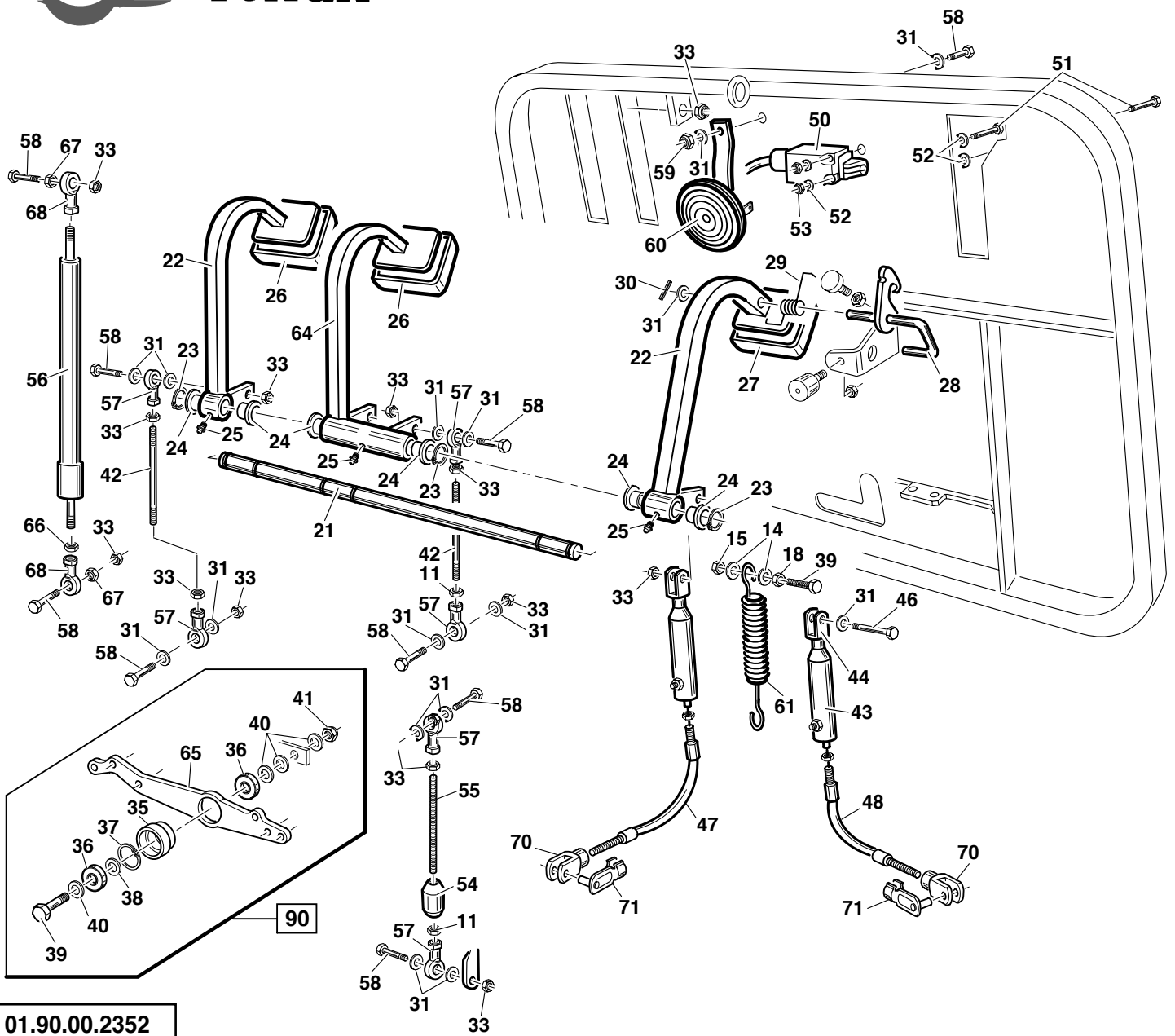
01.90.00.2352

Ref.	Leg.	Code	Q.ty	Ref.	Leg.	Code	Q.ty	Ref.	Leg.	Code	Q.ty
11		00.26.02.0060	12	33		00.26.04.0060	3	53		00.26.04.0020	2
14		00.68.01.0020	4	35		01.40.00.2170	1	54		01.40.00.2270	1
15		00.26.04.0040	1	36		00.22.00.0111	2	55		00.98.00.0008	0,16m
18		00.26.02.0040	1	37		00.03.09.0026	1	56		00.99.00.0220	1
21		01.40.00.2040	1	38		00.68.08.0233	1	57		00.78.01.0011	6
22		01.50.00.4910	2	39		00.92.03.1110	2	58		00.92.05.0110	6
23		00.03.10.0015	3	40		00.68.08.0233	4	59		00.26.02.1060	1
24		01.30.00.0010	6	41		00.26.04.0070	1	61		00.47.00.0010	1
25		00.42.00.0010	3	42		01.50.00.0270	2	64		01.50.00.6931	1
26		00.07.01.0130	2	43		01.50.00.5580	2	65		01.50.00.4943	1
27		00.07.01.0140	1	46		00.92.05.0160	1	66		00.26.02.1060	1
28		01.50.00.5550	1	47		00.25.01.0080	1	67		00.26.01.0060	2
29		00.47.00.0190	1	48		00.25.01.0090	1	68		00.78.01.0111	2
30		00.83.09.0014	1	51		00.90.02.0140	2	70		00.33.01.0020	2
31		00.68.01.0030	14	52		00.68.01.0009	2	71		00.33.01.0021	2
								90		01.50.00.4942	1



Gianni Ferrari

T6 - 30

06/06/2007

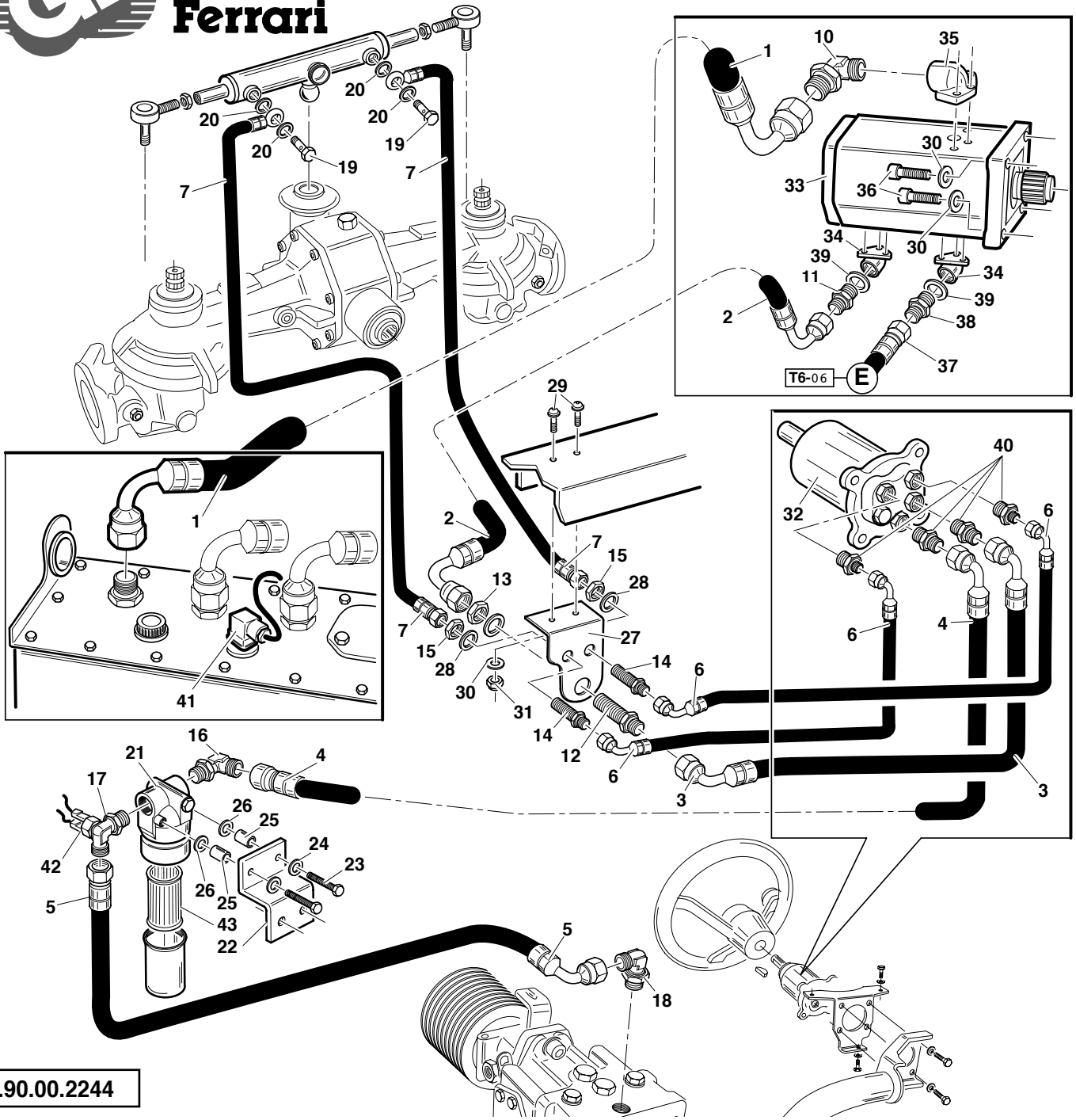

01.90.00.2244

Ref.	Leg.	Code	Q.ty	Ref.	Leg.	Code	Q.ty	Ref.	Leg.	Code	Q.ty
1		00.41.00.2130	1	17		00.41.00.0877	1	31		00.26.04.0060	2
2		00.41.00.2140	1	18		00.41.00.2205	1	32		00.41.00.0720	1
3		00.41.00.2150	1	19		00.41.00.0120	2	33		00.41.00.2120	1
4		00.41.00.2160	1	20		00.41.00.0060	4	34		00.41.00.0181	2
5		00.41.00.2170	1	21		00.32.03.0090	1	35		00.41.00.0183	1
6		00.41.00.2180	2	22		01.50.01.0890	1	36		00.90.06.0110	4
7		00.41.00.2190	2	23		00.92.03.0210	2	37		00.41.00.2490	1
10		00.41.00.0878	1	24		00.68.01.0020	2	38		00.41.00.0784	1
11		00.41.00.0113	1	25		01.40.00.1990	2	39		00.41.00.0071	2
12		00.41.00.0362	1	26		00.26.02.0040	2	40		00.41.00.0721	4
13		00.41.00.0372	1	27		01.50.01.0880	1	41		00.40.00.2160	1
14		00.41.00.0360	2	28		00.68.01.0060	2	42		00.40.00.2170	1
15		00.41.00.0370	2	29		00.90.06.3060	2	43		00.32.03.0092	1
16		00.41.00.0876	1	30		00.68.01.0030	4				

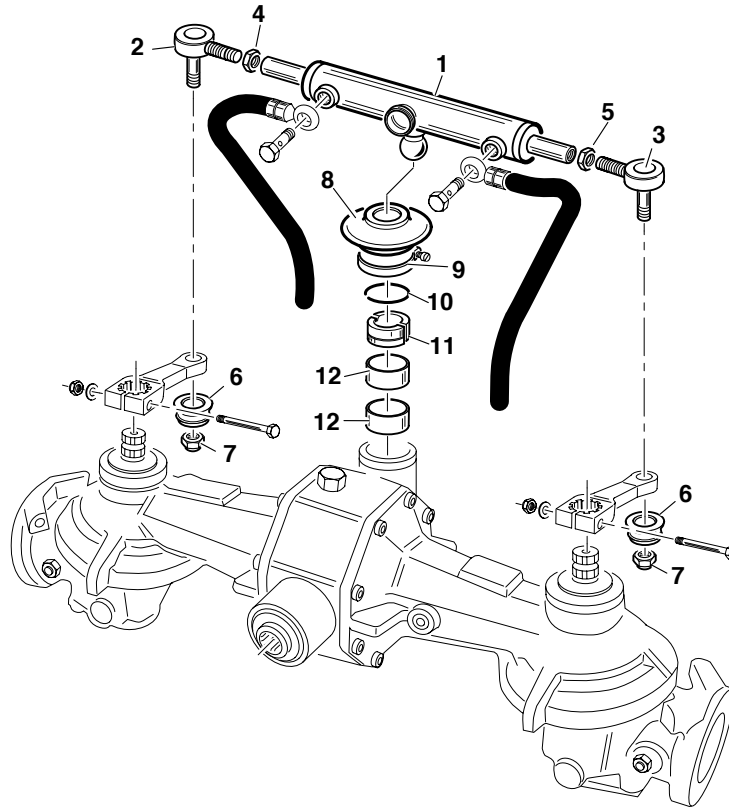
01.90.00.2241

Ref.	Leg.	Code	Q.ty
1		00.58.00.0140	1
2		00.78.10.0030	1
3		00.78.10.0040	1
4		00.26.03.2111	1
5		00.26.03.2110	1
6		00.07.01.0121	2
7		00.26.05.1090	2
8		00.07.01.0120	1
9		00.29.03.0010	1
10		01.20.00.0151	1
11		01.20.00.0150	1
12		00.24.02.4022	2



**Gianni
Ferrari**

T6 - 32

15/07/2006

01.90.00.2243

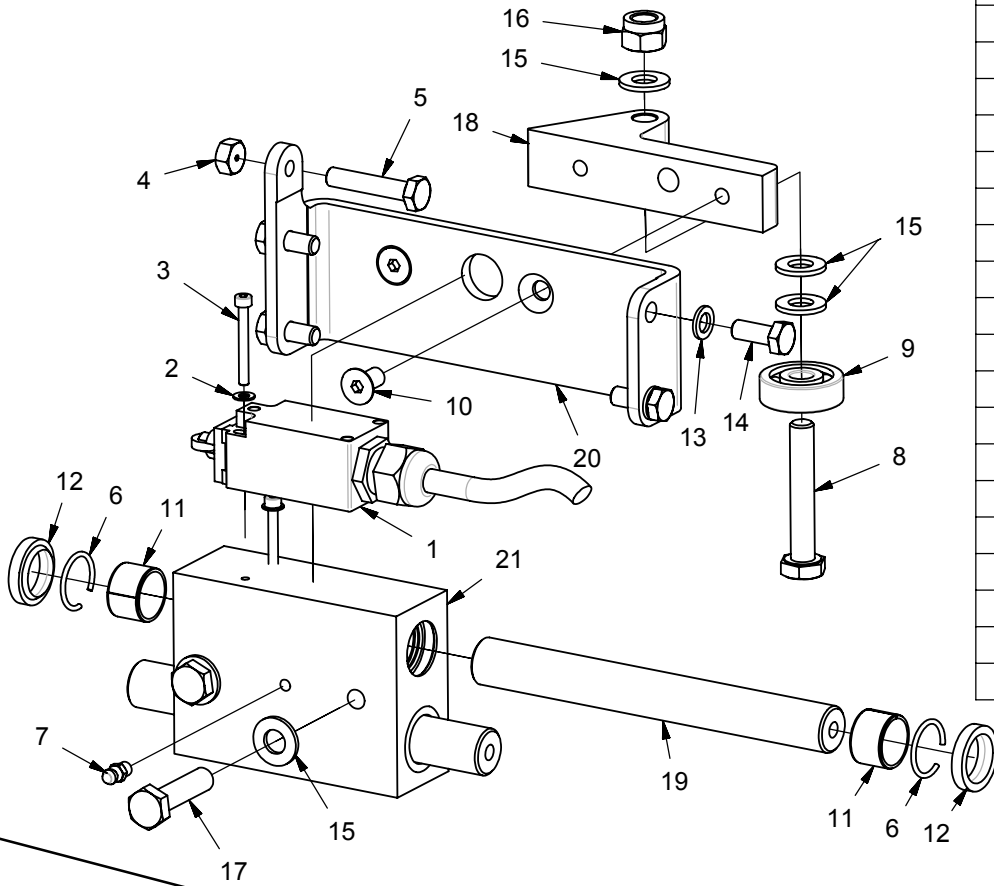

Ref.	Leg.	Code	Q.ty
21		01.40.00.3900	1
20		01.50.01.0550	1
19		01.40.00.3890	2
18		01.50.01.0560	1
17		00.92.06.1100	2
16		00.26.04.0070	1
15		00.68.01.0040	5
14		00.92.05.1070	4
13		00.68.01.0030	4
12		00.06.25.0020	4
11		00.10.20.0015	4
10		00.95.05.0020	2
9		00.22.00.0380	1
8		00.92.06.0140	1
7		00.42.00.0010	1
6		00.03.21.0025	4
5		00.92.05.1120	1
4		00.26.02.0060	1
3		00.90.02.0120	2
2		00.68.01.0009	2
1		00.40.00.0732	1

01.90.00.2242

Ref.	Leg.	Code	Q.ty
29		00.26.03.0090	1
28		00.26.03.0092	1
27		00.90.09.0152	1
26		00.78.01.0016	1
25		00.26.02.0100	2
24		00.07.01.0122	1
23		01.40.00.3870	1
22		01.40.00.3860	1
7		00.42.00.0010	1

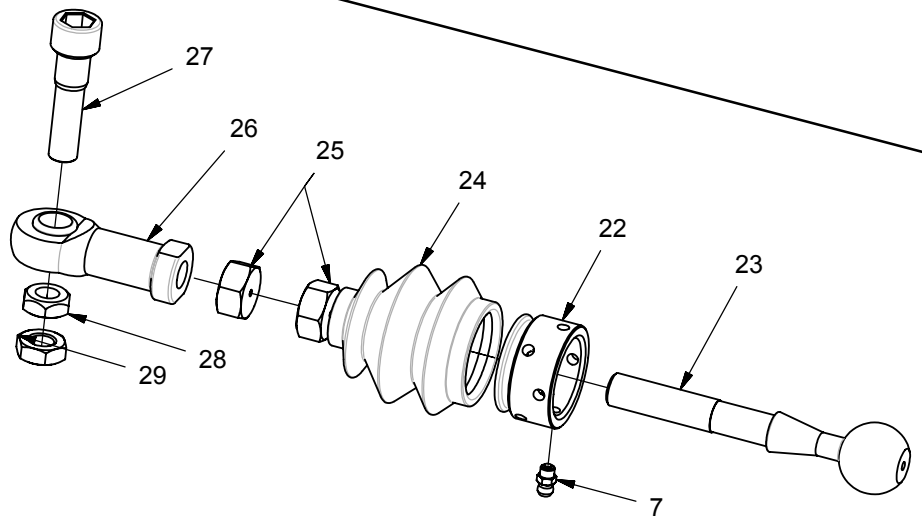

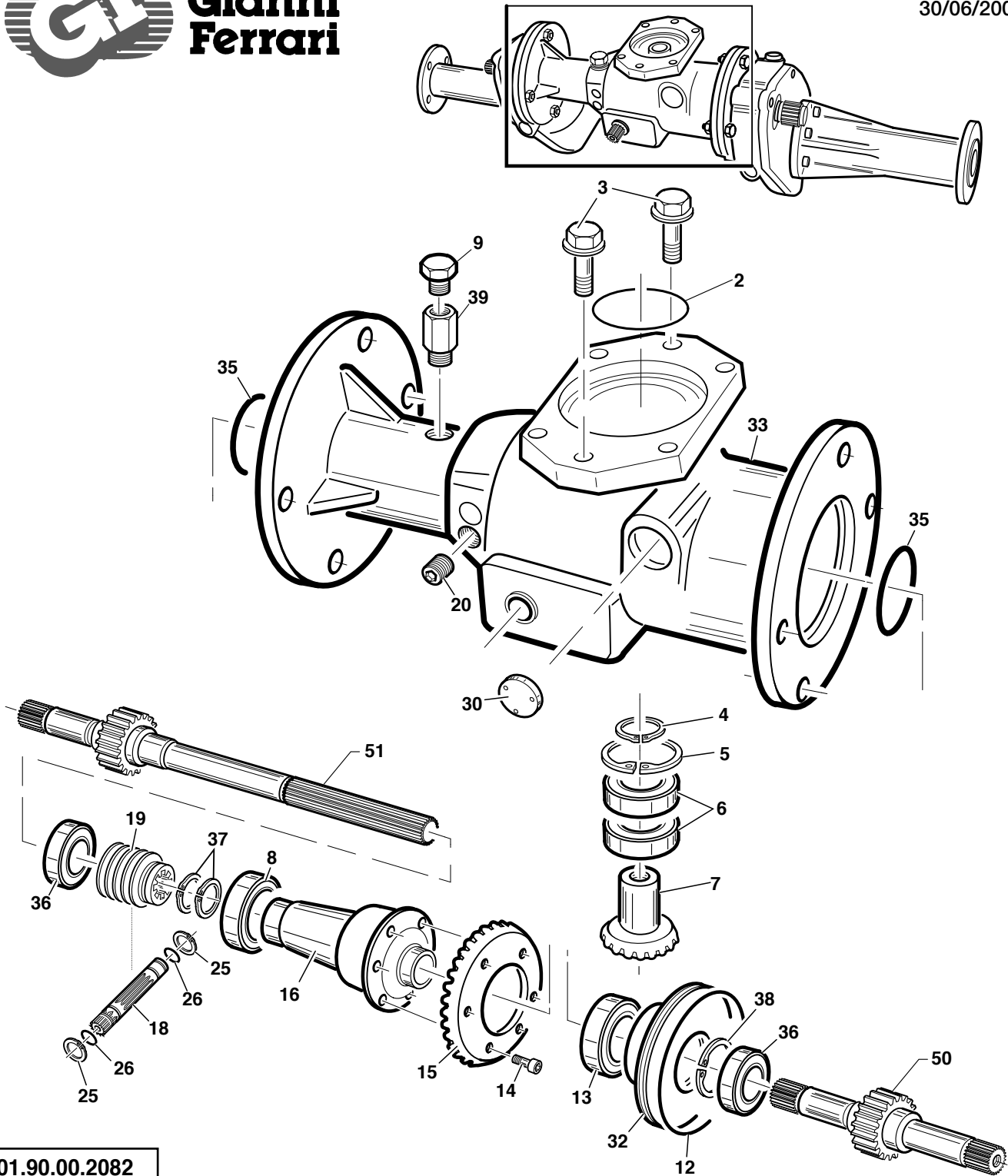

01.90.00.2082

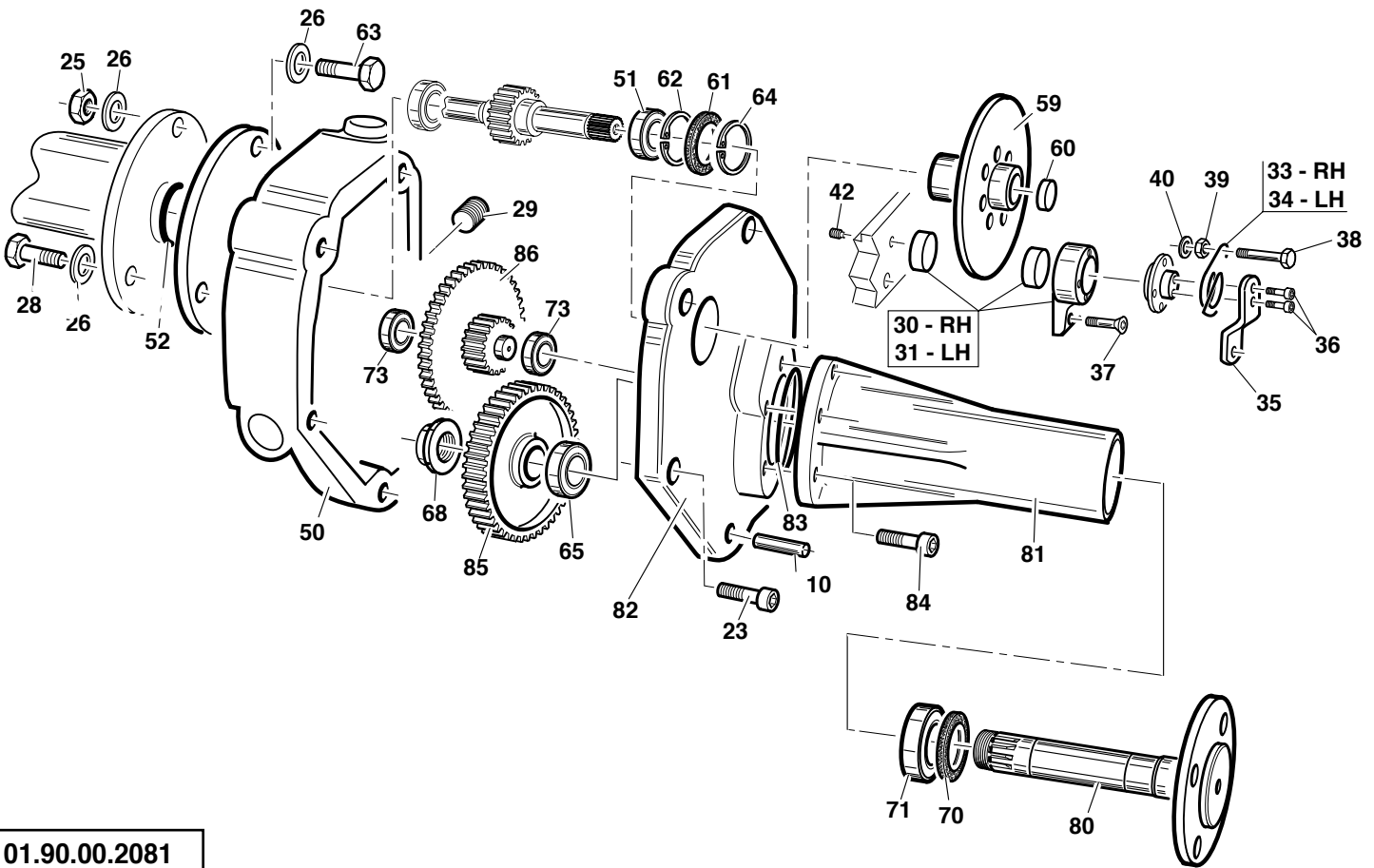
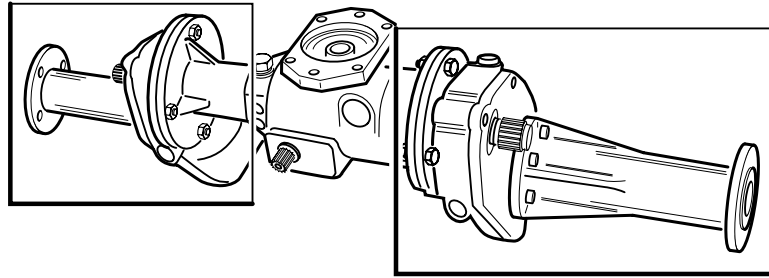
Ref.	Leg.	Code	Q.ty	Ref.	Leg.	Code	Q.ty	Ref.	Leg.	Code	Q.ty
2		00.06.07.0822	1	14		00.90.06.0050	6	33		01.01.00.0240	1
3		00.92.07.3090	2	15		01.40.00.1560	1	35		00.06.07.0521	1
4		00.03.00.0310	1	16		01.90.00.0730	1	36		00.22.25.5201	2
5		00.03.01.0072	1	18		01.40.00.1760	1	37		00.03.00.0310	2
6		00.22.35.7201	2	19		01.40.00.1810	1	38		00.03.01.0052	1
7		01.40.00.1570	1	20		00.85.02.0072	1	39		00.41.00.0935	1
8		00.22.45.7501	1	25		00.03.00.0160	3	50		01.40.00.3490	1
9		00.85.03.0013	1	26		00.06.07.0150	2	51		01.40.00.3500	1
12		00.06.07.1013	1	30		00.07.06.0032	1				
13		00.22.40.6801	1	32		01.01.00.0111	1				

01.90.00.2081

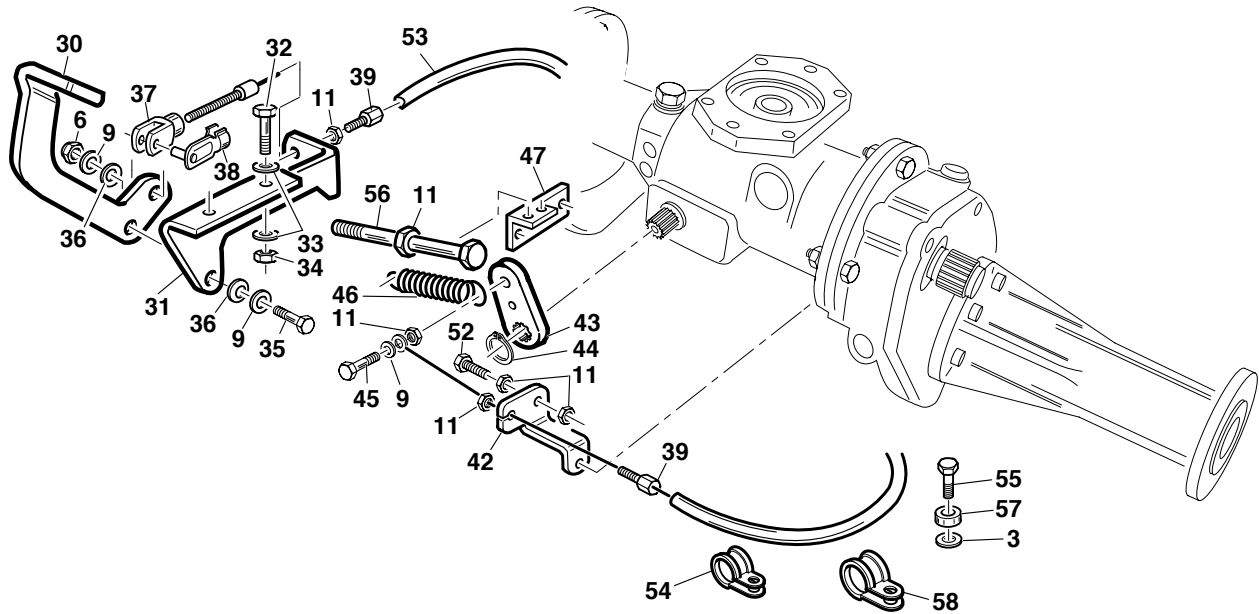
Ref.	Leg.	Code	Q.ty	Ref.	Leg.	Code	Q.ty	Ref.	Leg.	Code	Q.ty
10		00.83.14.2024	2	39		00.26.02.0060	2	70		00.05.45.0062	1
23		00.90.06.0130	14	40		00.68.01.0030	2	71		00.21.35.6201	1
25		00.26.02.0080	2	42		00.96.06.0030	2	73		00.20.17.4702	2
26		00.68.01.0040	4	50		01.01.00.0230	1	80		01.40.00.3300	1
28		00.90.07.0090	2	51		00.22.25.5201	1	81		01.01.00.0300	1
29		00.85.00.0090	2	52		00.06.07.0521	1	82		01.01.00.0310	1
30	RH	00.34.01.0060	1	59		01.40.00.2101	1	83		00.06.07.0600	1
31	LH	00.34.01.0070	1	60		00.07.06.0032	1	84		00.90.07.0111	6
33	RH	00.47.00.0280	1	61		00.05.00.0010	1	85		01.40.00.3480	1
34	LH	00.47.00.0290	1	62		00.03.01.0052	1	86		01.40.00.3470	1
35		01.50.00.5540	2	63		00.92.06.0120	2				
36		00.90.04.0070	4	64		00.06.07.0202	1				
37		00.95.05.0070	2	65		00.21.30.6201	1				
38		00.92.05.0160	2	68		01.40.00.2530	1				

01.90.00.1294

Ref.	Leg.	Code	Q.ty	Ref.	Leg.	Code	Q.ty
3		00.68.01.0040	3	42		01.50.00.5381	1
6		00.26.04.0060	1	43		01.50.00.5391	1
9		00.68.01.0030	3	44		00.03.00.0160	1
11		00..26.02.0060	5	45		00.92.05.1100	1
30		01.50.00.4924	1	46		00.47.00.0060	1
31		01.50.00.4923	1	47		01.50.00.2500	1
32		00.92.03.1070	3	52		00.92.05.1160	1
33		00.68.02.0030	6	53		00.25.01.0110	1
34		00.26.04.0040	3	54		00.29.01.0075	1
35		00.92.05.1110	1	55		00.90.07.0100	2
36		00.48.00.0112	2	56		00.92.05.0250	1
37		00.33.01.0020	1	57		01.50.00.0770	1
38		00.33.01.0021	1	58		00.29.01.0099	1

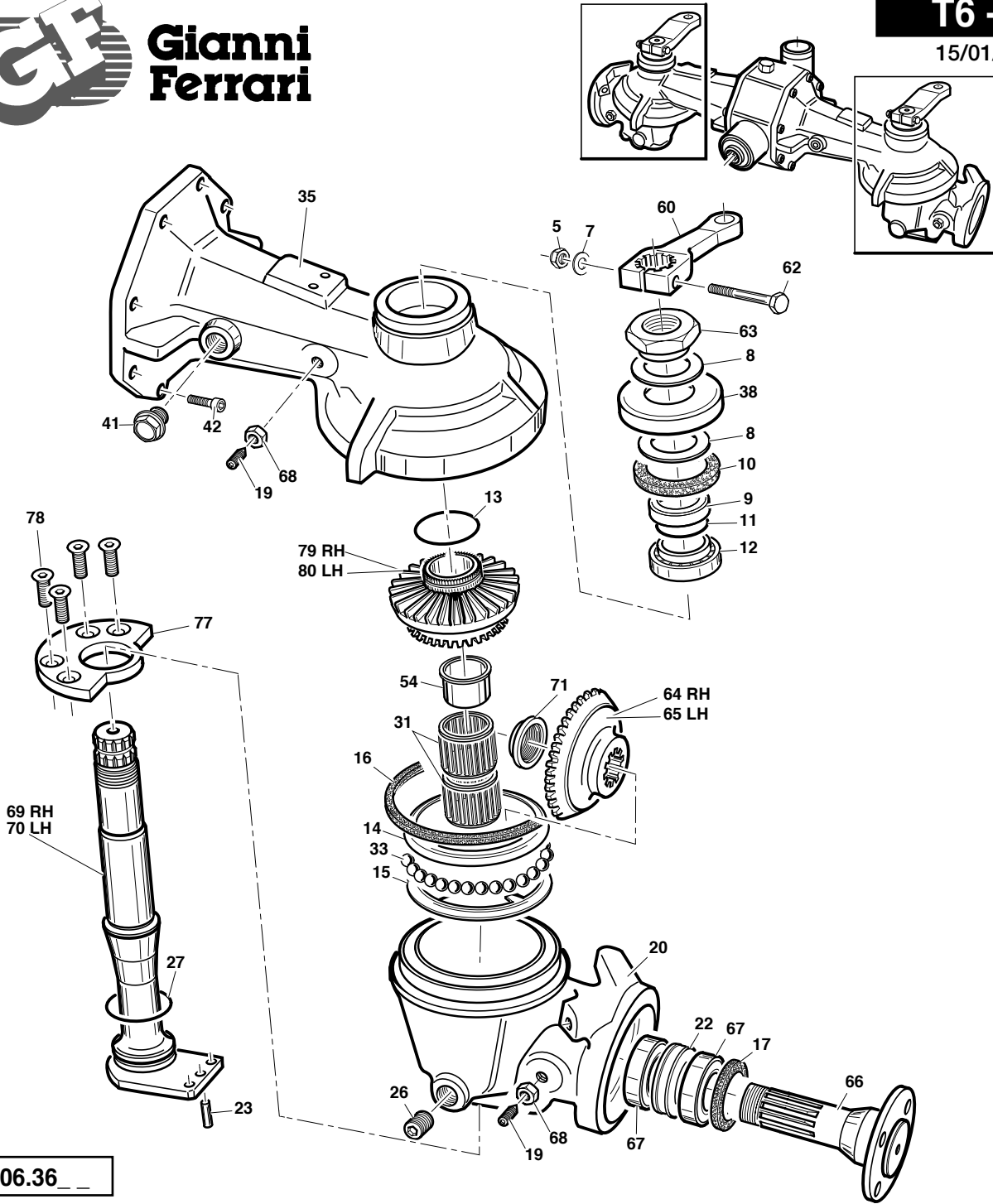
89.00.06.36

Ref.	Leg.	Code	Q.ty	Ref.	Leg.	Code	Q.ty	Ref.	Leg.	Code	Q.ty
5		00.26.04.1070	1	22		01.40.00.1720	1	64	RH	01.40.00.3320	1
7		00.68.01.0040	1	23		00.83.16.1020	1	65	LH	01.40.00.3330	1
8		00.48.00.0230	2	26		00.85.02.0072	1	66		01.40.00.3310	1
9		01.40.00.1730	1	27		00.06.07.0360	1	67		00.21.35.7201	2
10		00.05.40.0055	1	31		00.35.32.4025	2	68		00.26.02.0080	1
11		00.06.07.0298	1	33		00.76.00.0111	35	69	RH	01.50.01.0250	1
12		00.21.30.5501	1	35		01.01.00.0160	1	70	LH	01.50.01.0260	1
13		00.03.20.0055	1	38		01.50.00.4590	1	71		01.40.00.2530	1
14		01.50.00.6020	1	41		00.85.03.0002	1	77		01.40.00.3430	1
15		01.50.00.6030	1	42		00.90.06.0110	8	78		00.95.05.0040	4
16		00.05.00.0157	1	54		01.20.00.0110	1	79	RH	01.40.00.3400	1
17		00.05.45.0072	1	60		01.01.00.0330	1	80	LH	01.40.00.3410	1
19		00.96.06.2100	2	62		00.92.06.2151	1				
20		01.01.00.0140	1	63		01.40.00.3790	1				

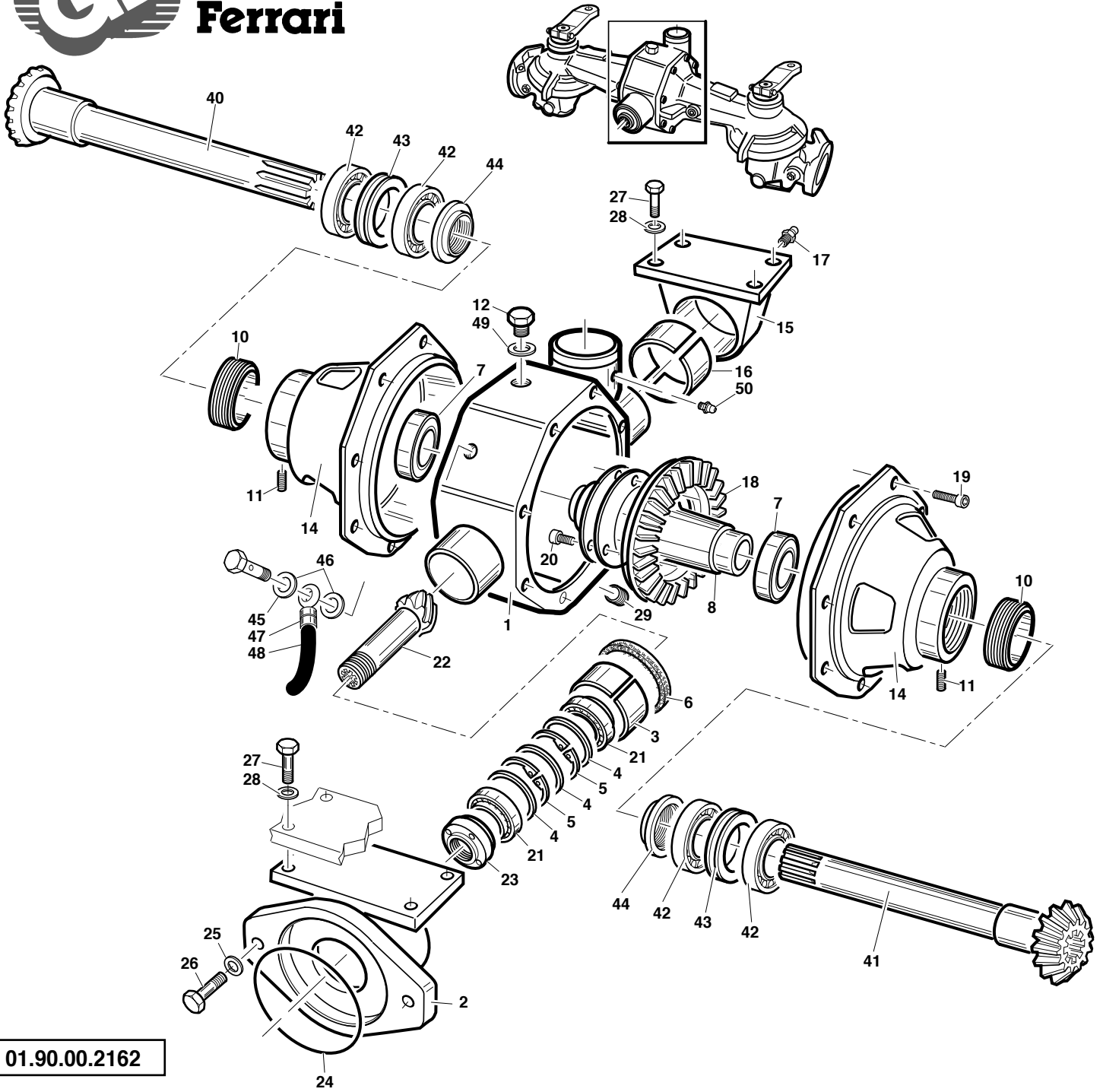
01.90.00.2162

Ref.	Leg.	Code	Q.ty	Ref.	Leg.	Code	Q.ty	Ref.	Leg.	Code	Q.ty
1		01.01.00.0120	1	16		00.10.45.0030	1	40	RH	01.40.00.3340	1
2		01.50.00.4580	1	17		00.42.00.0010	1	41	LH	01.40.00.3350	1
3		00.10.70.0040	1	18		01.40.00.1580	1	42		00.21.25.5201	4
4		01.40.00.1740	3	20		00.90.06.0080	6	43		01.40.00.3420	2
5		00.03.01.0055	2	21		00.21.30.5501	2	44		01.40.00.2530	2
6		00.05.70.0085	1	22		01.40.00.1590	1	45		00.41.00.0200	1
7		00.21.40.6801	2	23		01.40.00.1750	1	46		00.41.00.0210	2
8		01.90.00.0880	1	24		00.06.07.1013	1	47		00.41.00.0190	1
10		01.40.00.1770	2	25		00.68.01.0050	2	48	ML	00.89.07.0006	1,00
11		00.96.05.2020	2	26		00.92.07.3090	2	49		00.41.00.0071	1
12		00.85.02.0004	1	27		00.92.06.1080	8	50		00.42.00.0020	1
14		01.01.00.0130	2	28		00.6801.0040	8				
15		01.50.00.4570	1	29		00.85.02.0072	1				

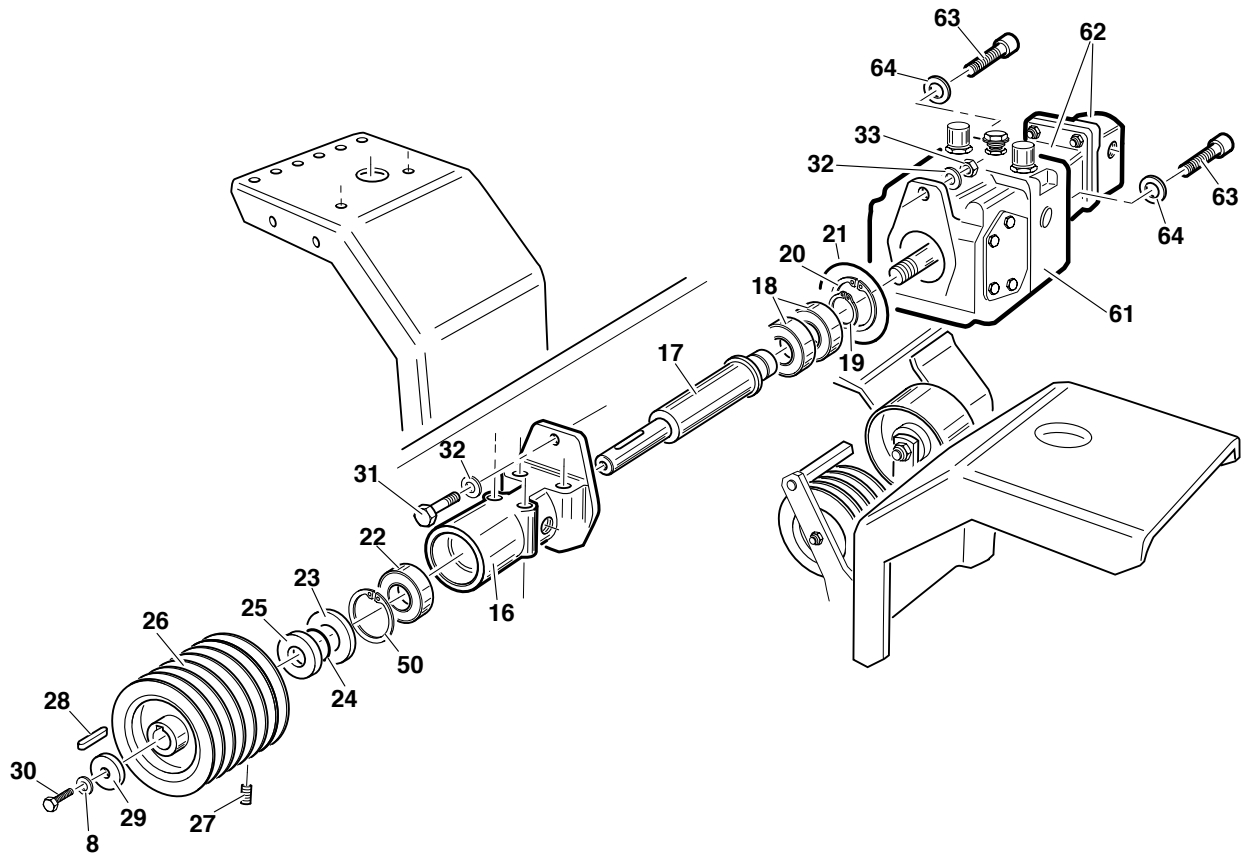
01.90.00.2281

Ref.	Leg.	Code	Q.ty	Ref.	Leg.	Code	Q.ty	Ref.	Leg.	Code	Q.ty
8		00.68.01.0040	1	23		00.05.40.3062	1	31		00.90.09.0170	2
16		01.01.00.0350	1	24		00.06.07.0239	1	32		00.68.01.0060	4
17		01.40.00.1840	1	25		01.40.00.2250	1	33		00.26.04.0090	2
18		00.22.00.0280	2	26		00.61.00.0650	1	50		00.03.01.0062	1
19		00.03.00.0260	1	27		00.96.05.0030	2	61		00.41.00.0700	1
20		00.03.01.0055	1	28		00.43.00.0110	1	62		00.41.00.2110	1
21		00.06.07.1013	1	29		00.68.08.0303	1	63		00.93.03.0050	2
22		00.20.25.6202	1	30		00.92.06.1060	1	64		00.68.01.0040	2

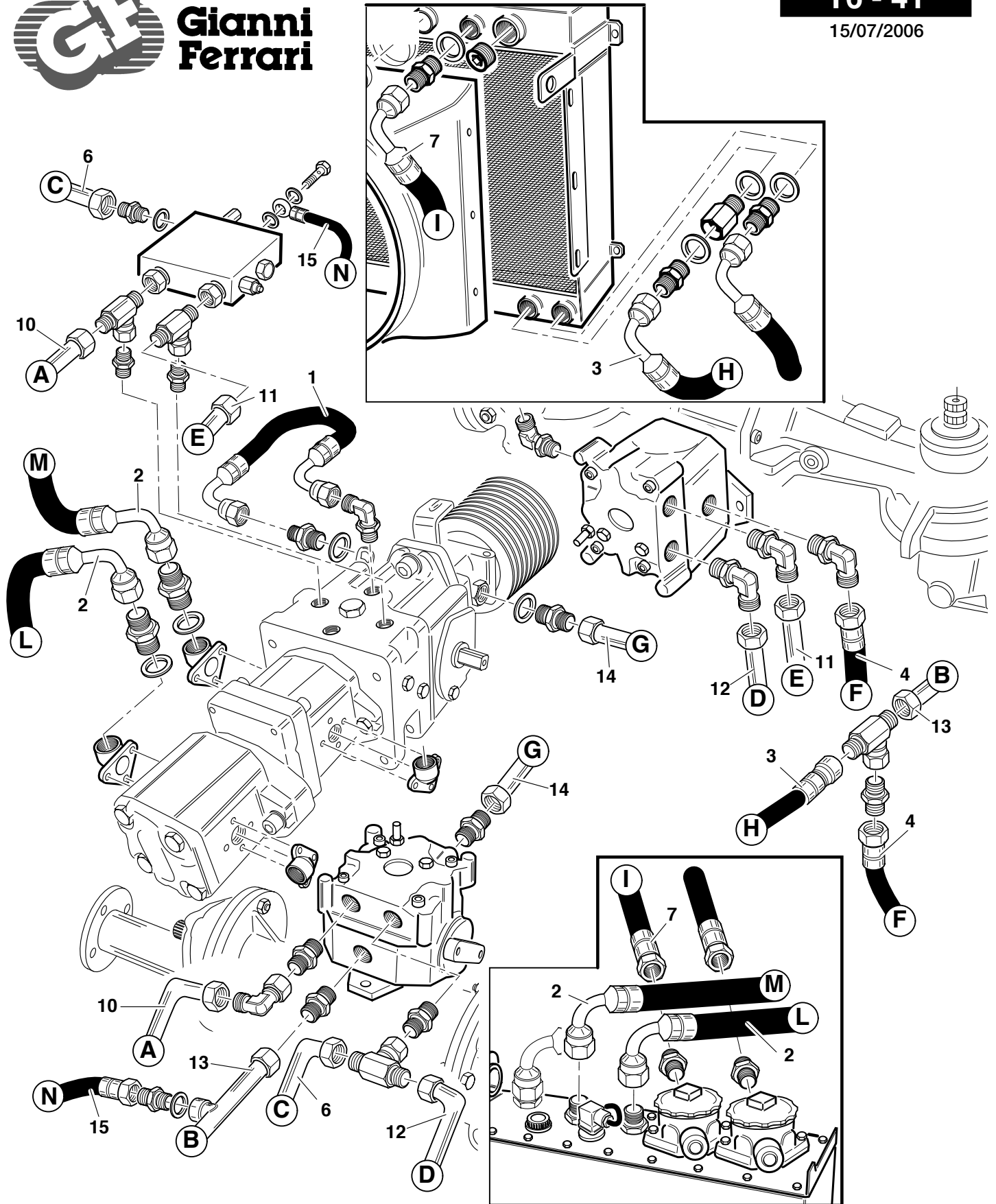
01.90.00.2261

Ref.	Leg.	Code	Q.ty	Ref.	Leg.	Code	Q.ty	Ref.	Leg.	Code	Q.ty
1		00.41.00.2510	1	6		00.41.00.2540	1	12		00.41.00.2590	1
2		00.41.00.2130	2	7		00.41.00.2810	1	13		00.41.00.2600	1
3		00.41.00.2400	1	10		00.41.00.2570	1	14		00.41.00.2610	1
4		00.41.00.2520	1	11		00.41.00.2580	1	15		00.41.00.2531	1



Gianni Ferrari

T6 - 42

20/11/2006

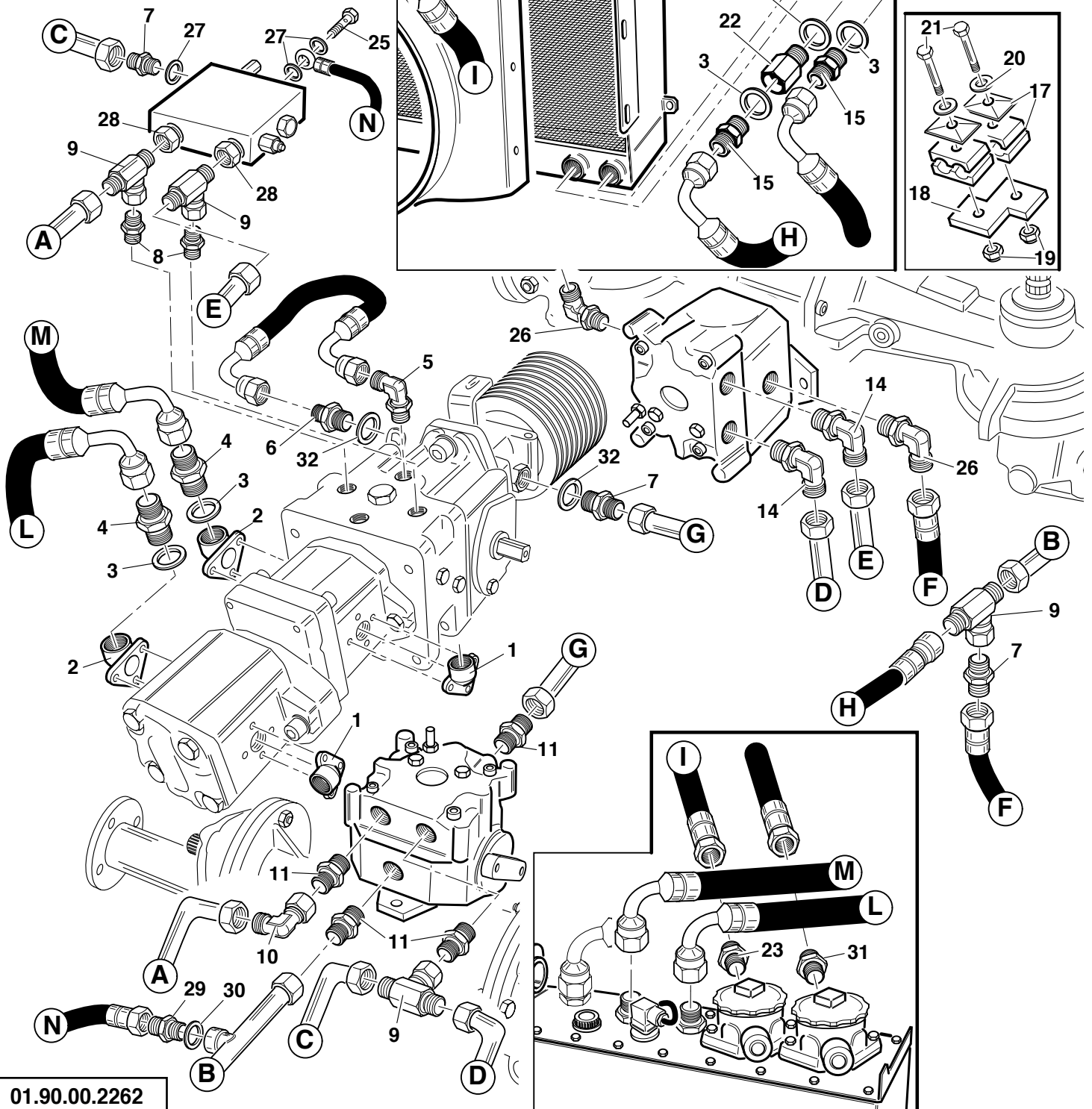

01.90.00.2262

Ref.	Leg.	Code	Q.ty	Ref.	Leg.	Code	Q.ty	Ref.	Leg.	Code	Q.ty
1		00.41.00.0181	2	11		00.41.00.1276	4	24		00.41.00.0074	2
2		00.41.00.0183	2	14		00.41.00.2206	2	25		00.41.00.0125	1
3		00.41.00.0073	4	15		00.41.00.0823	1	26		00.41.00.2867	2
4		00.41.00.0115	2	17		00.41.00.0442	4	27		00.41.00.0071	3
5		00.41.00.2205	1	18		01.50.01.1080	2	28		00.41.00.1545	2
6		00.41.00.0819	1	19		00.92.05.0160	4	29		00.41.00.0450	1
7		00.41.00.0820	3	20		00.68.01.0030	4	30		00.41.00.0060	2
8		00.41.00.1275	2	21		00.26.04.0060	4	31		00.41.00.0826	1
9		00.41.00.1245	4	22		00.41.00.0934	1	32		00.41.00.1289	2
10		00.41.00.0945	1	23		00.41.00.0116	2				

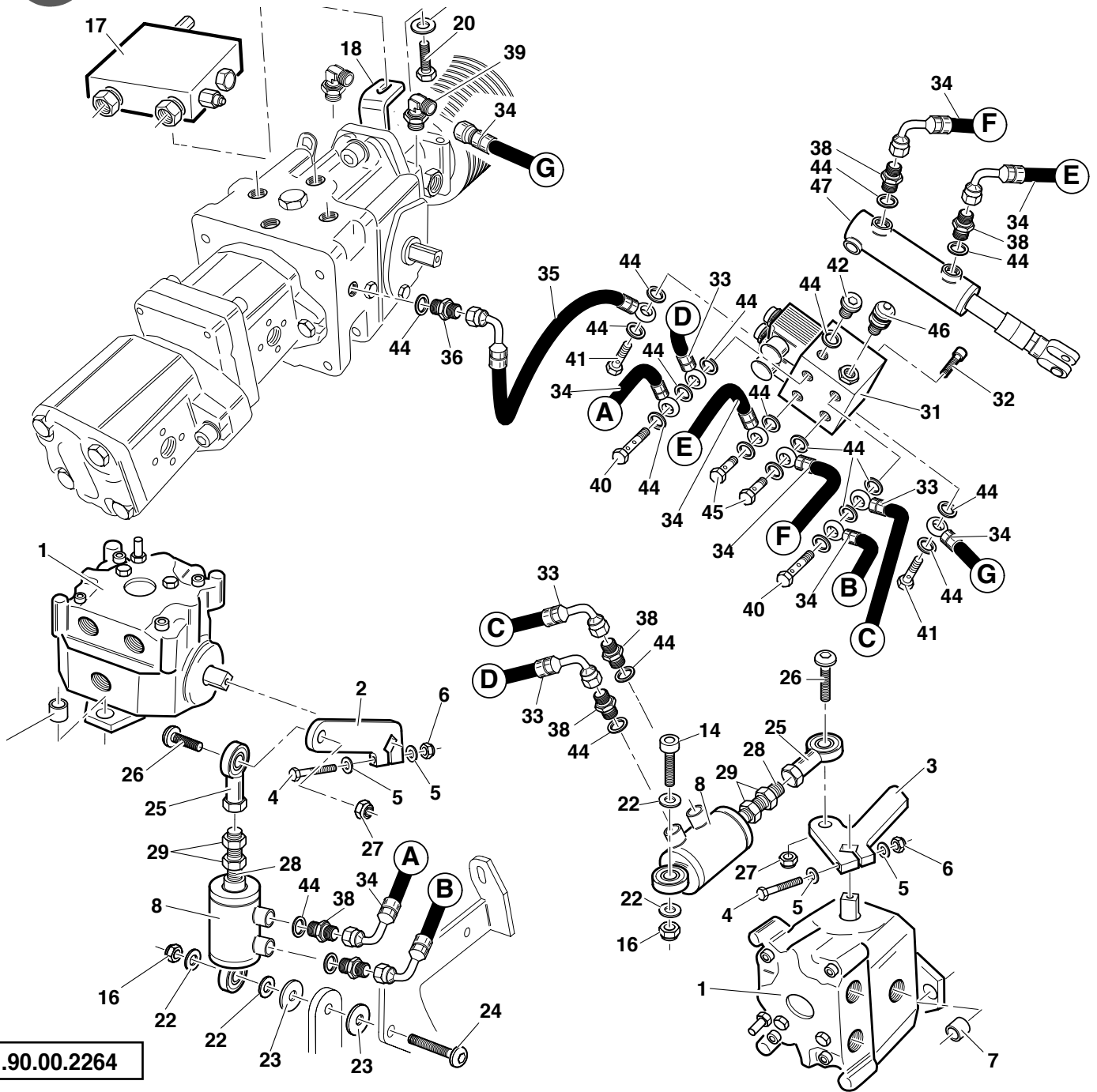

01.90.00.2264

Ref.	Leg.	Code	Q.ty	Ref.	Leg.	Code	Q.ty	Ref.	Leg.	Code	Q.ty
1		00.54.00.1100	2	19		00.68.02.0050	1	33		00.41.00.2700	2
2		01.50.01.1140	1	20		00.92.05.1070	1	34		00.41.00.2710	5
3		01.50.01.1150	1	22		00.68.08.0321	4	35		00.41.00.2720	1
4		00.92.05.0151	2	23		00.68.08.0346	2	36		00.41.00.0710	1
5		00.68.01.0030	4	24		00.90.08.3170	1	38		00.41.00.0780	8
6		00.26.04.0060	2	25		00.78.01.0114	2	39		00.41.00.0873	1
7		01.40.00.3990	4	26		00.90.08.3140	2	40		00.41.00.0126	2
8		00.58.00.0150	2	27		00.26.05.0080	2	41		00.41.00.0120	2
14		00.90.08.0130	1	28		00.96.07.0160	2	42		00.85.02.0071	1
16		00.26.04.0080	2	29		00.26.03.0090	4	44		00.41.00.0060	20
17		00.41.00.2620	1	31		00.41.00.2250	1	45		00.41.00.0122	2
18		01.50.01.1510	1	32		00.90.06.0080	2	46		00.41.00.3085	1
								47		00.58.00.0040	1

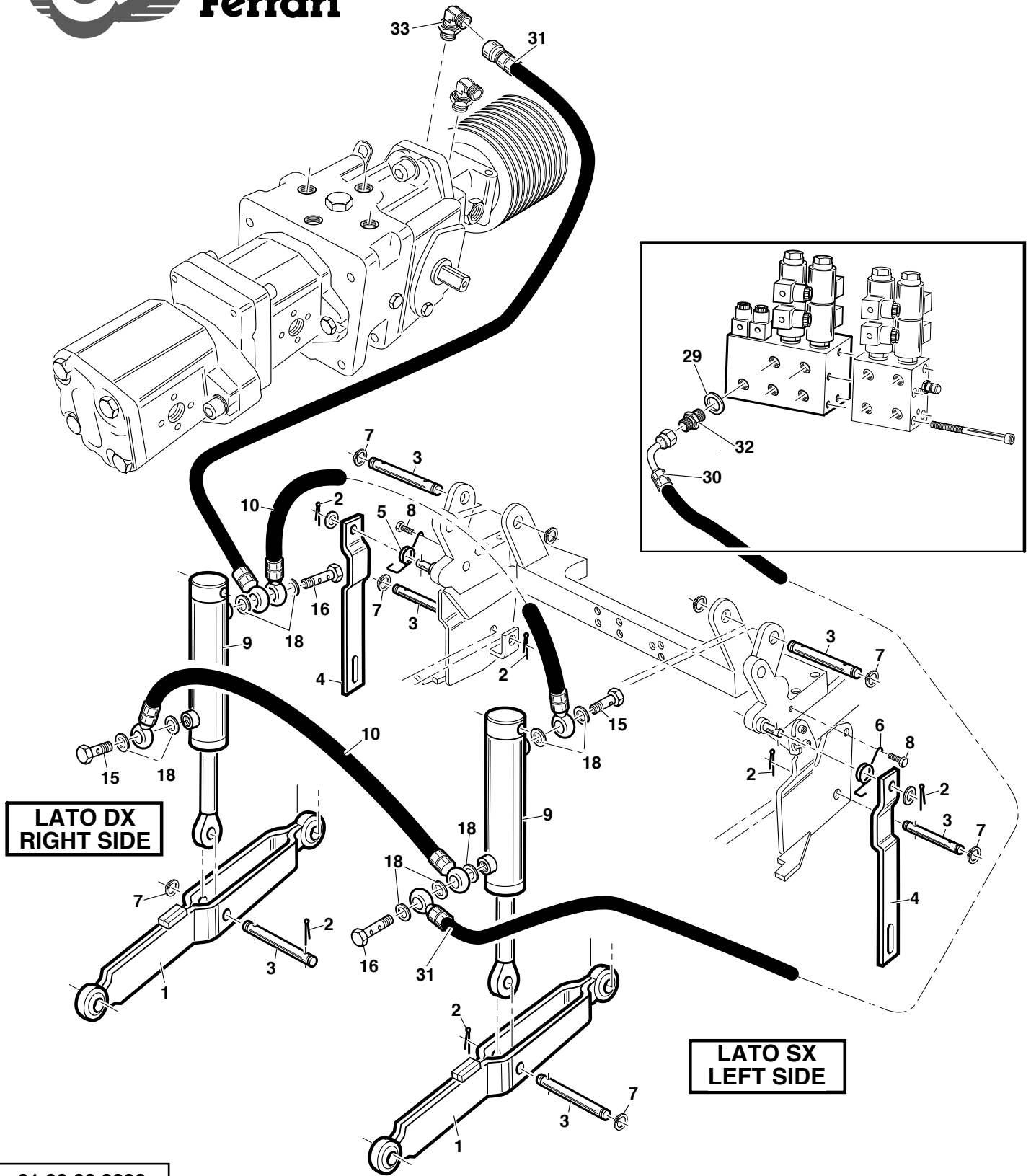
01.90.00.2290

Ref.	Leg.	Code	Q.ty	Ref.	Leg.	Code	Q.ty	Ref.	Leg.	Code	Q.ty
1		01.50.00.7420	2	7		00.03.10.0016	4	18		00.41.00.0060	10
2		00.18.04.0075	6	8		00.92.05.1040	2	29		00.41.00.0070	1
3		01.40.00.2690	6	9		00.58.00.0100	2	30		00.41.00.2630	1
4		01.50.00.7570	2	10		00.41.00.1670	2	31		00.41.00.2710	1
5		00.47.00.0290	1	15		00.41.00.0120	2	32		00.41.00.0452	1
6		00.47.00.0280	1	16		00.41.00.0124	2	33		00.41.00.0873	1



P R O F E S S I O N A L M O W E R S

GIANNI FERRARI s.r.l. • Via Vespucci, 53 (Zona Ind. Ranaro) • 42046 REGGIOLO (RE) Italy • Tel. 0522 / 973697 • Fax 0522 / 973707

www.gianniferrari.com [e-mail:info@gianniferrari.com](mailto:info@gianniferrari.com)